

PRESSES A CREMAILLERES MANUELLES



Caractéristiques techniques :

	400 CL	2000 CL	5500 CL
Force	1 kn	3 kn	5 kn
Course maximale	30/45 mm	35/60 mm	40/75 mm
Dimension du socle	150 x 120 mm	190 x 190 mm	290 x 290 mm
Hauteurs utiles	0 - 175 mm	50 - 435 mm	70 - 530 mm
Profondeur col de cygne	85 mm	125 mm	200 mm
Diamètre porte-outil	Ø 12 mm	Ø 16 mm	Ø 16 mm
Poids	9 kg	33 kg	78 kg



Plan

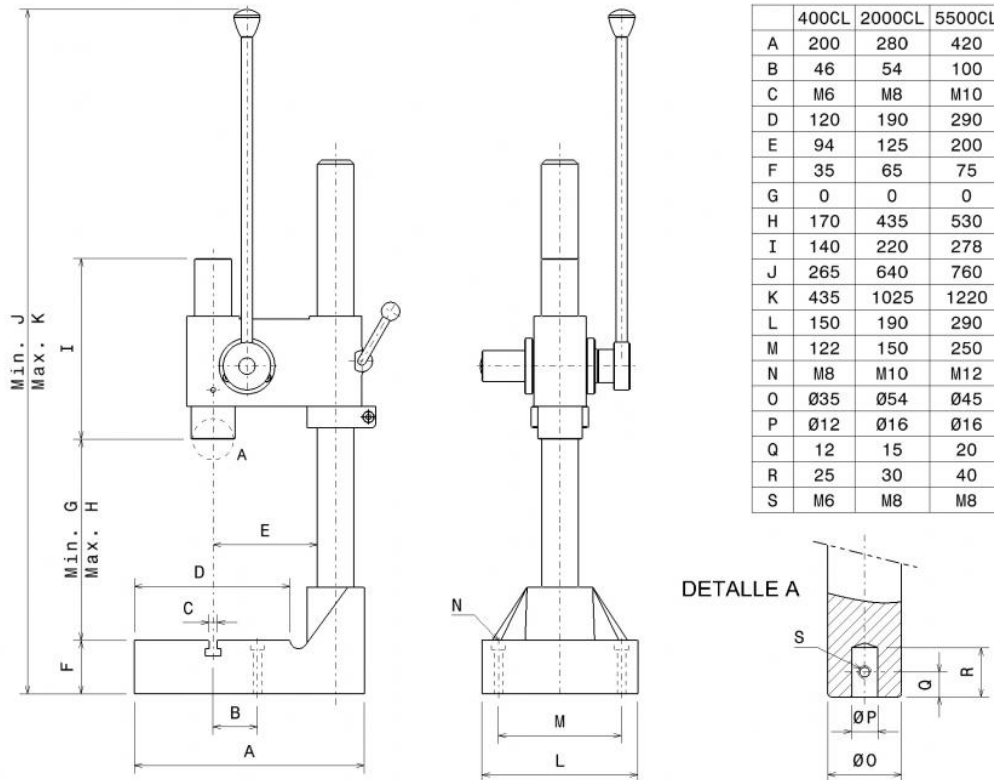

Applications

