

Type G and GD according to DIN 808 with plain bearing

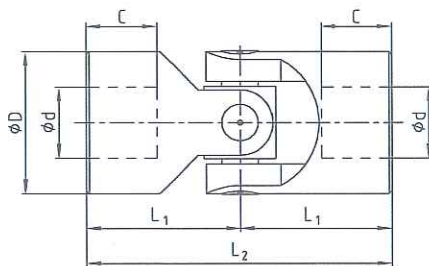

- Suitable for every application in the range of general engineering up to a maximum speed of 1000 r
- Type G precision single joint
- Type GD precision double joint
- Maximum articulation angle 45° for each joint
- Bearings designed as plain bearings
- Available with finish bore H7 – on request with keyway, hexagon bore or square bore
- Also available as clamping hub

Precision single joint G



Precision double joint GD

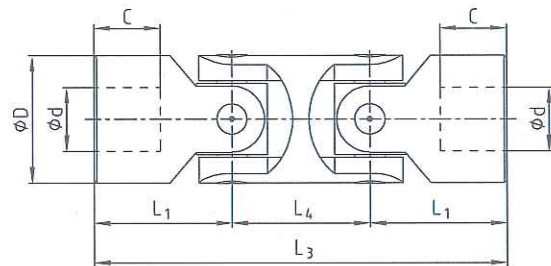

Finish bores:

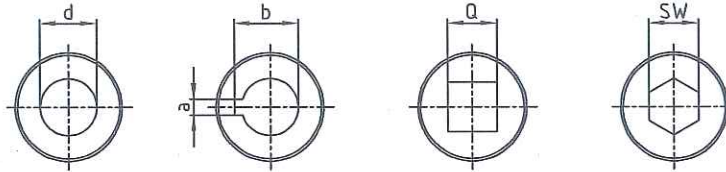

Type G and GD

Type G and GD																
Types and size															Weight [kg]	
Size G	DIN description G	Size GD	DIN description GD	d [H7]	D	L ₂	L ₁	C	L ₄	L ₃	a [JS9]	b	Q [H8]	SW [H8]	G	GD
01 G	E6 x 16-G	01 GD	D6 x 16-G	6	16	34	17	8	22	56	2	7,0	6	6	0,05	0,08
02 G	E8 x 16-G	02 GD	D8 x 16-G	8	16	40	20	11	22	62	2	9,0	8	8	0,05	0,08
03 G	E10 x 22-G	03 GD	D10 x 22-G	10	22	48	24	12	26	74	3	11,4	10	10	0,10	0,15
04 G	E12 x 25-G	04 GD	D12 x 25-G	12	25	56	28	13	30	86	4	13,8	12	12	0,16	0,25
05 G	E14 x 28-G	05 GD	D14 x 28-G	14	28	60	30	14	36	96	5	16,3	14	14	0,20	0,40
1 G	E16 x 32-G	1 GD	D16 x 32-G	16	32	68	34	16	36	104	5	18,3	16	16	0,30	0,45
2 G	E18 x 36-G	2 GD	D18 x 36-G	18	36	74	37	17	40	114	6	20,8	18	18	0,45	0,70
3 G	E20 x 42-G	3 GD	D20 x 42-G	20	42	82	41	18	46	128	6	22,8	20	20	0,60	1,00
4 G	E22 x 45-G	4 GD	D22 x 45-G	22	45	95	47,5	22	50	145	6	24,8	22	22	0,95	1,55
5 G	E25 x 50-G	5 GD	D25 x 50-G	25	50	108	54	26	55	163	8	28,3	25	25	1,20	2,00
6 G	E30 x 58-G	6 GD	D30 x 58-G	30	58	122	61	29	68	190	8	33,3	30	30	1,85	2,90
6 G1	E32 x 58-G	6 GD1	D32 x 58-G	32	58	130	65	33	68	198	10	35,3	30	30	2,00	3,00
7 G	E35 x 70-G	7 GD	D35 x 70-G	35	70	140	70	35	72	212	10	38,3	-	-	3,15	4,75
8 G	E40 x 80-G	8 GD	D40 x 80-G	40	80	160	80	39	85	245	12	43,3	-	-	4,60	7,20
9 G	E50 x 95-G	9 GD	D50 x 95-G	50	95	190	95	46	100	290	14	53,8	-	-	7,60	12,0

Ordering example:

04 G	Ø12	Ø12 keyway DIN
Size/type of joint	Finish bore (H7)	Finish bore (H7) keyway to DIN 6885 sheet 1 (JS9)

Type H and HD according to DIN 808 with needle bearing



- Suitable for every application in the range of general engineering up to a maximum speed of 4000 rpm
- Type H precision single joint
- Type HD precision double joint
- Maximum articulation angle 45°
- High dynamic load - small bearing clearance
- Maintenance-free due to needle bearing
- Available with finish bore H7 – on request with keyway, hexagon bore or square bore
- Also available as clamping hub

Precision single joint H

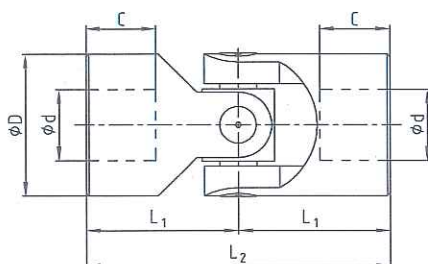

Precision double joint HD

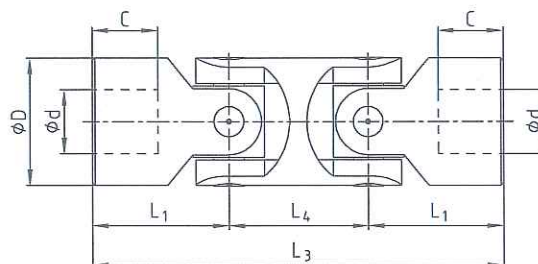

Finish bores:

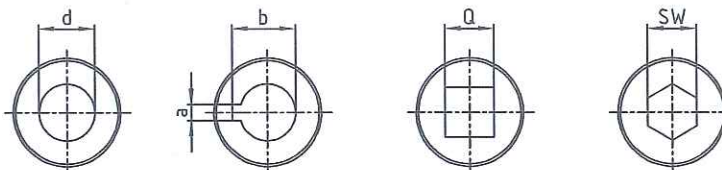

Type H and HD																
Types and size				Dimensions [mm]											Weight [kg]	
Size H	DIN description H	Size HD	DIN description HD	d [H7]	D	L ₂	L ₁	C	L ₄	L ₃	a [JS9]	b	Q [H8]	SW [H8]	H	HD
03 H	E10 x 22-W	03 HD	D10 x 22-W	10	22	48	24	12	26	74	3	11,4	10	10	0,10	0,15
04 H	E12 x 25-W	04 HD	D12 x 25-W	12	25	56	28	13	30	86	4	13,8	12	12	0,16	0,25
05 H	E14 x 28-W	05 HD	D14 x 28-W	14	28	60	30	14	36	96	5	16,3	14	14	0,20	0,40
1 H	E16 x 32-W	1 HD	D16 x 32-W	16	32	68	34	16	36	104	5	18,3	16	16	0,30	0,45
2 H	E18 x 36-W	2 HD	D18 x 36-W	18	36	74	37	17	40	114	6	20,8	18	18	0,45	0,70
3 H	E20 x 42-W	3 HD	D20 x 42-W	20	42	82	41	18	46	128	6	22,8	20	20	0,60	1,00
4 H	E22 x 45-W	4 HD	D22 x 45-W	22	45	95	47,5	22	50	145	6	24,8	22	22	0,95	1,55
5 H	E25 x 50-W	5 HD	D25 x 50-W	25	50	108	54	26	55	163	8	28,3	25	25	1,20	2,00
6 H	E30 x 58-W	6 HD	D30 x 58-W	30	58	122	61	29	68	190	8	33,3	30	30	1,85	2,90
6 H1	E32 x 58-W	6 HD1	D32 x 58-W	32	58	130	65	33	68	198	10	35,3	30	30	2,00	3,00
7 H	E35 x 70-W	7 HD	D35 x 70-W	35	70	140	70	35	72	212	10	38,3	-	-	3,15	4,75
8 H	E40 x 80-W	8 HD	D40 x 80-W	40	80	160	80	39	85	245	12	43,3	-	-	4,60	7,20
9 H	E50 x 95-W	9 HD	D50 x 95-W	50	95	190	95	46	100	290	14	53,8	-	-	7,60	12,0

Ordering example:

1 H	Ø16	Ø16 keyway DIN
Size/type of joint	Finish bore (H7)	Finish bore (H7) keyway to DIN 6885 sheet 1 (JS9)

Type GA and HA acc. to DIN 808 with plain and needle bearing (extendable)



- Precision double joint - extendable, maximum articulation angle 45° for each joint
- Bridging larger shaft distances
- Type GA (plain bearing) $n_{max.} = 1000$ rpm
- Type HA (needle bearing) $n_{max.} = 4000$ rpm
- Available with quick locking GR; HR
- Available with finish bore H7 – on request available with key-way, thread for setscrews, square or hexagon bore
- Also available as clamping hub

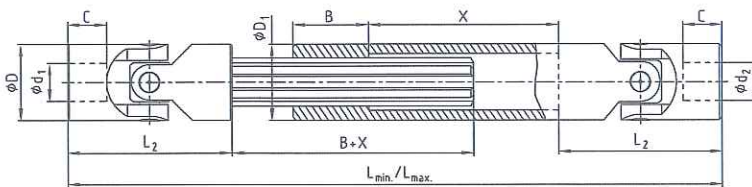

Finish bores:

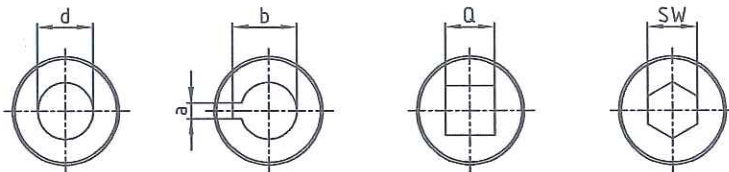

Preferred lengths									
Size	Dimensions [mm]								
	L _{min.} / L _{max.}								
03	140	160	180	230					
	170	200	240	330					
04	160	180	200	220	250	280	300		
	190	225	270	300	355	420	450		
05	170	180	200	220	250	280	300	350	400
	200	220	260	300	350	420	450	550	650
1	190	210	240	250	275	300	380	400	
	220	250	320	350	390	430	590	630	
2	230	250	270	290	300	400	500		
	280	320	370	400	415	620	820		
3	250	270	290	320	380	420	500		
	300	340	380	440	560	640	800		
4	250	270	290	330	350	470			
	280	320	350	430	470	710			
5	295	310	350	380	420	460	500		
	345	375	450	500	590	660	745		
6	330	350	370	400	450	500	540		
	380	420	455	510	620	720	795		

Type GA with plain bearing $n_{max.} = 1000$ rpm and type HA with needle bearing $n_{max.} = 4000$ rpm													
Size		Dimensions [mm]										Splines shaft	D ₁
GA	HA	d ₁ , d ₂ [H7]	D	L ₂	C	L _{min.} / L _{max.} / X	B	a [JS9]	b	Q [H8]	SW [H8]		
01 GA	-	6	16	34	8	← →	25	2	7,0	6	6	SW8	16
02 GA	-	8	16	40	11	← →	25	2	9,0	8	8	SW8	16
03 GA	03 HA	10	22	48	12	← →	30	3	11,4	10	10	11 x 14 Z6	22
04 GA	04 HA	12	25	56	13	← →	40	4	13,8	12	12	13 x 16 Z6	26
05 GA	05 HA	14	28	60	14	← →	40	5	16,3	14	14	13 x 16 Z6	29
1 GA	1 HA	16	32	68	16	← →	40	5	18,3	16	16	16 x 20 Z6	32
2 GA	2 HA	18	36	74	17	← →	40	6	20,8	18	18	18 x 22 Z6	37
3 GA	3 HA	20	42	82	18	← →	45	6	22,8	20	20	21 x 25 Z6	42
4 GA	4 HA	22	45	95	22	← →	50	6	24,8	22	22	23 x 28 Z6	47
5 GA	5 HA	25	50	108	26	← →	50	8	28,3	25	25	26 x 32 Z6	52
6 GA	6 HA	30	58	122	29	← →	60	8	33,3	30	30	32 x 38 Z8	58
7 GA	7 HA	35	70	140	35	← →	70	10	38,3	-	-	36 x 42 Z8	70
8 GA	8 HA	40	80	160	39	← →	80	12	43,3	-	-	42 x 48 Z8	80
9 GA	9 HA	50	95	190	46	← →	90	14	53,8	-	-	46 x 54 Z8	95

Calculation of mounting lengths L and X (stroke)

$$\text{Stroke } X \geq (L_{max} - 2 \cdot L_2 - B) / 2$$

$$L_{min.} \geq (L_{max} + 2 \cdot L_2 + B) / 2$$

$$\text{Minimum dimension } L_{min.} = L_2 + B + X + L_2$$

Ordering example:

3 GA	d ₁ = Ø20	d ₂ = Ø20 keyway DIN	550/650
Size/type of joint	Finish bore (H7)	Finish bore (H7), keyway to DIN 6885 sheet 1 (JS9)	Mounting length L _{min.} /L _{max.}

Type X and XD acc. to DIN 808 with plain bearing (stainless steel 1.4301)



- Suitable for every application in the range of general engineering up to a maximum speed of 300 rpm
- Type X precision single joint
- Type XD precision double joint
- Maximum articulation angle 45° for each joint
- Available with finish bore H7 – on request with keyway, hexagon bore or square bore

Precision single joint X

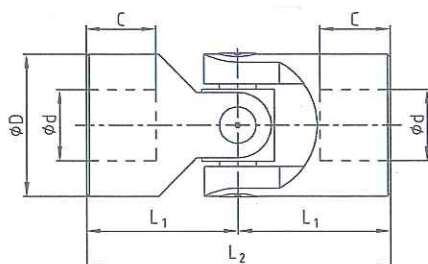

Precision double joint XD

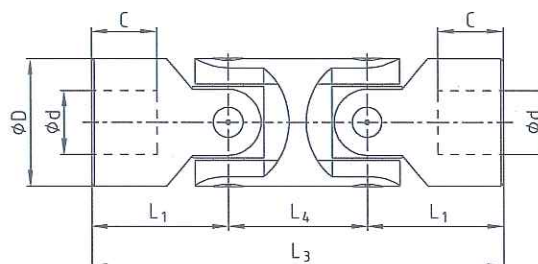

Finish bores:

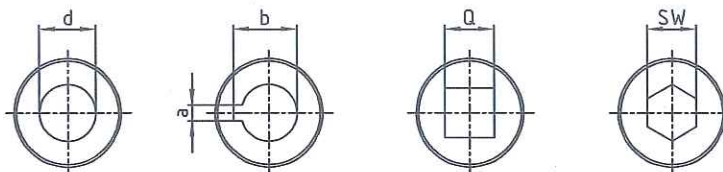

Type and size				Dimensions [mm]											Weight [kg]	
Size X	DIN description X	Size XD	DIN description XD	d [H7]	D	L ₂	L ₁	C	L ₄	L ₃	a [JS9]	b	Q [H8]	SW [H8]	X	XD
01 X	E6 x 16-G	01 XD	D6 x 16-G	6	16	34	17	8	22	56	2	7,0	6	6	0,05	0,08
02 X	E8 x 16-G	02 XD	D8 x 16-G	8	16	40	20	11	22	62	2	9,0	8	8	0,05	0,08
03 X	E10 x 22-G	03 XD	D10 x 22-G	10	22	48	24	12	26	74	3	11,4	10	10	0,10	0,15
04 X	E12 x 25-G	04 XD	D12 x 25-G	12	25	56	28	13	30	86	4	13,8	12	12	0,16	0,25
1 X	E16 x 32-G	1 XD	D16 x 32-G	16	32	68	34	16	36	104	5	18,3	16	16	0,30	0,45
3 X	E20 x 42-G	3 XD	D20 x 42-G	20	42	82	41	18	46	128	6	22,8	20	20	0,60	1,00
5 X	E25 x 50-G	5 XD	D25 x 50-G	25	50	108	54	26	55	163	8	28,3	25	25	1,20	2,00
6 X	E30 x 58-G	6 XD	D30 x 58-G	30	58	122	61	29	68	190	8	33,3	30	30	1,85	2,90

Ordering example:

04 X	Ø12	Ø12 keyway DIN
Size/type of joint	Finish bore (H7)	Finish bore (H7) keyway to DIN 6885 sheet 1 (JS9)

Type GR and HR with quick locking

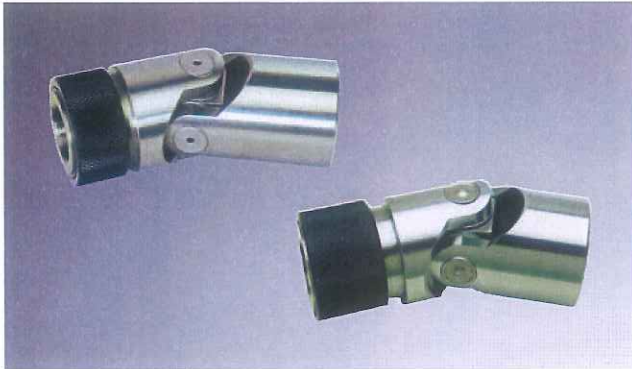

- Precision single joint with quick locking (separable)
- Type GR with plain bearing $n_{max.} = 1000$ rpm
- Type HR with needle bearing $n_{max.} = 4000$ rpm
- Maximum articulation angle 45°
- Quick locking (d_2) available with H7 bore and keyway to DIN 6885 sheet 1 – JS9 or hexagon bore

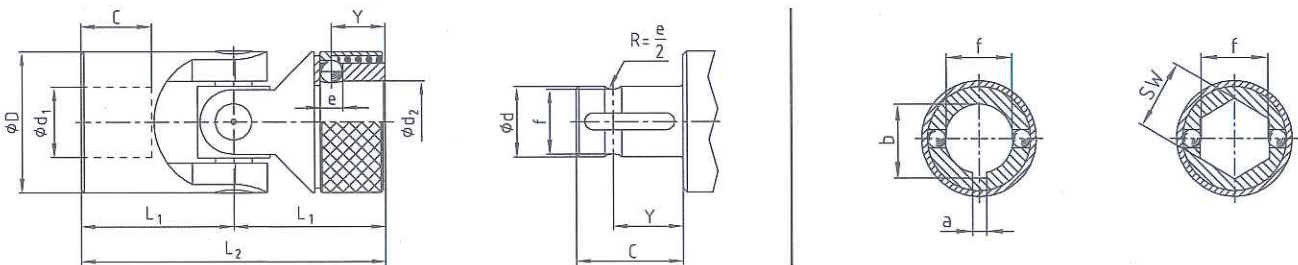

Type GR with plain bearing $n_{max.} = 1000$ rpm and type HR with needle bearing $n_{max.} = 4000$ rpm												
Size		Dimensions [mm]										
GR	HR	d_1, d_2 [H7]	D	L_2	L_1	C	Y	e	f	a [JS9]	b	SW [H8]
02 GR	-	8	16	52	26	14	9,5	3,5	7,0	2	9,0	8
03 GR	03 HR	10	22	62	31	17	11,5	4,0	8,7	3	11,0	10
04 GR	04 HR	12	25	74	37	21	13,5	4,0	11,0	4	13,3	12
05 GR	05 HR	14	25	74	37	21	13,5	4,0	13,0	5	15,3	14
1 GR	1 HR	16	32	86	43	24	14,0	6,35	14,8	5	17,3	16
2 GR	2 HR	18	36	96	48	28	19,0	8,0	16,0	6	19,8	18
3 GR	3 HR	20	42	108	54	31	19,0	8,0	18,0	6	22,3	20
4 GR	4 HR	22	45	120	60	34	20,5	10,0	20,0	6	24,8	22
5 GR	5 HR	25	50	132	66	38	20,5	10,0	23,0	8	28,3	25
6 GR	6 HR	30	58	166	83	49	25,0	10,0	28,0	8	33,3	30

Protection bush for joints type G, H, GA, HA and jX

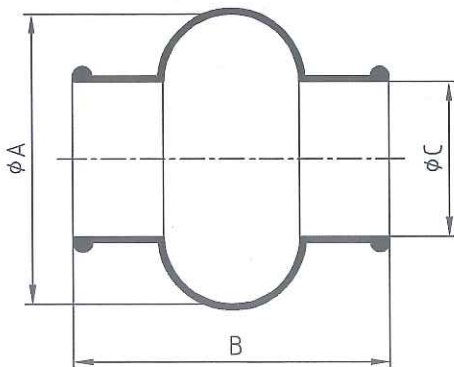

Protection bush				
Size	Precision joints	A	B	C
M 01	01 G, 01 X	28	34	15
M 02	02 G, 02 X	32	40	16,5
M 03	03 G, 03 H, 03 GA, 03 HA, 03 X	40	45	20,5
M 04	04 G, 04 H, 04 GA, 04 HA, 04 X	48	50	24,5
M 05	05 G, 05 H, 05 GA, 05 HA	52	56	27,5
M 1	1 G, 1 H, 1 GA, 1 HA, 1 X	56	65	30,5
M 2	2 G, 2 H, 2 GA, 2 HA	66	72	35,5
M 3	3 G, 3 H, 3 GA, 3 HA, 3 X	75	82	40,0
M 4	4 G, 4 H, 4 GA, 4 HA	84	95	45,0
M 5	5 G, 5 H, 5 GA, 5 HA, 5 X	92	108	50,0
M 6	6 G, 6 G1, 6 H, 6 H1, 6 GA, 6 HA, 6 X	100	122	56,0

Ordering example:	03 HR	$d_1 = \varnothing 10$	$d_2 = \varnothing 10$ keyway DIN
	Size/type of joint	Finish bore (H7)	Finish bore (H7) keyway to DIN 6885 sheet 1 (JS9)

Selection and determination of size acc. to DIN 808 with plain/needle bearing

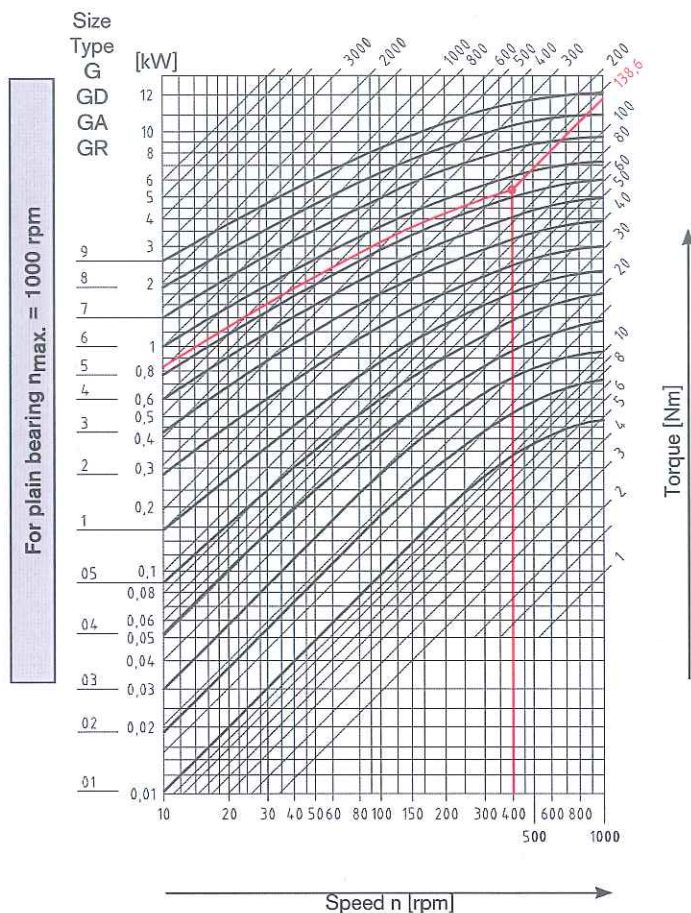

Selection of precision joints¹⁾ type G, GD, GA, GR (max. 1000 rpm)

45°	4,0
40°	3,3
35°	2,6
30°	2,2
25°	1,8
20°	1,5
15°	1,25
10°	1,00
5°	0,8

The selection of the precision joints with plain bearing is based on the driving torque, taking into account a correction value which depends on the articulation angle α and the operating speed. For the extendable joints in addition the overall length and the speed have to be considered to determine the size (please consult with KTR engineering department).

Torque · correction value = selected torque M_t

Example of selection		
Driving torque M_t [Nm]	Correction value for articulation angle α	Selected torque; Selection of size acc. to table
63	30°	
63	2,2	63 Nm · 2,2 = 138,6 Nm

Operating speed = 400 rpm

The selection of the size according to the table is based on the driving torque (63 Nm) · correction value (30° = 2,2) = 138,6 Nm and the operating speed of 400 rpm.
Selected: Joint size 6

Torque [Nm] = 9550 · Power [kW] / speed [rpm]

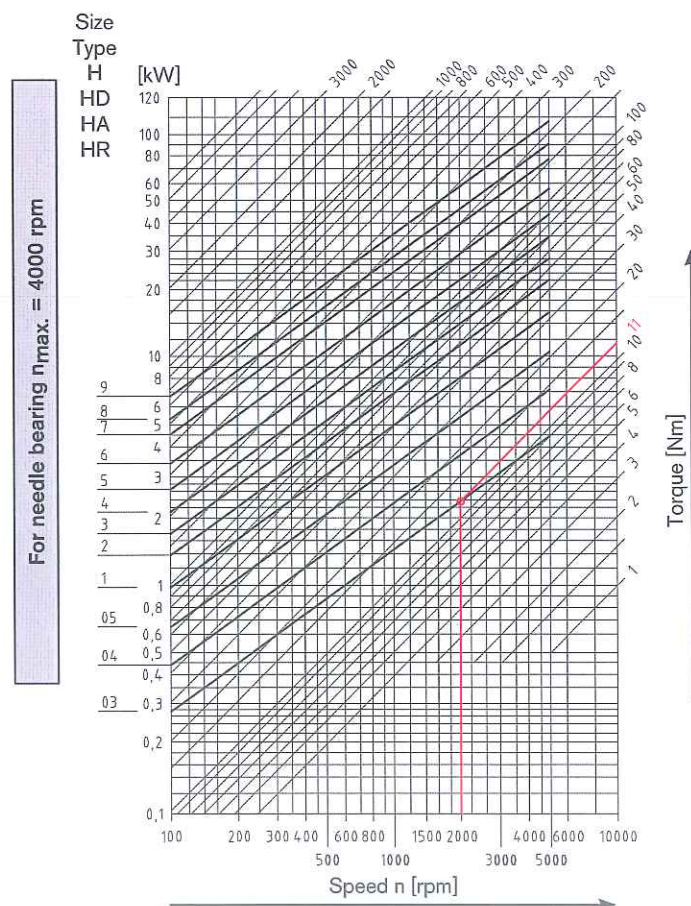

Selection of precision joints¹⁾ type H, HD, HA, HR (max. 4000 rpm)

45°	4,0
40°	3,3
35°	2,5
30°	2,0
25°	1,4
20°	1,25
15°	1,1
10°	1,00
5°	0,8

The selection of the precision joints with needle bearing is based on the driving torque, taking into account a correction value which depends on the articulation angle α and the operating speed. For the extendable joints in addition the overall length and the speed have to be considered to determine the size (please consult with KTR engineering department).

Torque · correction value = selected torque M_t

Example of selection		
Driving torque M_t [Nm]	Correction value for articulation angle α	Selected torque; Selection of size acc. to table
8,8	20°	
8,8	1,25	8,8 Nm · 1,25 = 11 Nm

Operating speed = 2000 rpm

The selection of the size according to the table is based on the driving torque (8,8 Nm) · correction value (20° = 1,25) = 11 Nm and the operating speed of 2000 rpm. Selected: Joint size 03

Torque [Nm] = 9550 · Power [kW] / speed [rpm]

¹⁾ Please note for selection: bending angle · speed ≤ 40000