

2.0	RIDUTTORI EPICICLOIDALI SERIE EP	PLANETARY GEARBOXES EP SERIES	PLANETENGETRIEBE SERIE EP	
2.1	Caratteristiche	<i>Characteristics</i>	Merkmale	28
2.2	Designazione	<i>Designation</i>	Bezeichnung	29
2.3	Selezione	<i>Selection</i>	Getriebeauswahl	29
2.4	Gioco angolare	<i>Backlash</i>	Spiel	29
2.5	Carichi radiali e assiali su albero lento	<i>Radial and axial loads on output shaft</i>	Radial-und Axiallasten an der Ausgangswelle	30
2.6	Lubrificazione	<i>Lubrication</i>	Schmierung	30
2.7	Momento d'inerzia	<i>Moment of inertia</i>	Trägheitsmoment	31
2.8	Dati tecnici	<i>Technical data</i>	Technische Daten	34
2.9	Dimensioni	<i>Dimensions</i>	Abmessungen	34
2.10	Istruzioni per il montaggio del motore	<i>Instructions for the motor assem- bling</i>	Anleitung für Motoranbau	44



2.1 Caratteristiche

La serie di riduttori epicicloidali EP è il risultato di un ottimo rapporto tra economicità del prezzo e garanzia di precisione delle caratteristiche di funzionamento. I nostri riduttori sono stati realizzati per un'utilizzazione prevalente sulle seguenti applicazioni:

- Macchine utensili
- Macchine per la lavorazione del legno
- Linee transfer
- Macchine da stampa
- Macchine automatiche per confezionamento ed imballaggio
- Automazioni
- Manipolatori
- Macchine serigrafiche
- Guide lineari

La gamma dei riduttori è costituita da 5 grandezze (55, 75, 90, 120 e 155), a 1 e 2 stadi di riduzione, ognuna con due tipi di alberi uscita (tipo A e tipo T) e flange uscita di tipo A, T e Q.

Corpo: costruito in acciaio, garantisce robustezza e una elevata affidabilità nel tempo.

Flange: le flange in entrata ed in uscita sono costruite in alluminio e sono disponibili in molteplici varianti costruttive.

Alberi: sono costruiti in acciaio legato bonificato.

Ingranaggi: in acciaio legato da cementazione e tempra, con dentature rettificata.

Cuscinetti: di elevata qualità opportunamente dimensionati per garantire elevate durate e silenziosità di funzionamento.

2.1 Characteristics

The planetary gearbox EP series is the result of the outstanding ratio competitive price / precision guaranteed with regard to operating features.

Our gearboxes are manufactured for prevailing utilization in the following applications:

- *Machine tools*
- *Woodworking machines*
- *Transfer machines*
- *Printing machines*
- *Automatic packing and packaging machines*
- *Automation*
- *Mechanical hands*
- *Silk-screen process machines*
- *Linear guides*

The EP series is available in 5 sizes (55, 75, 90, 120 and 155), with 1 or 2 reduction stages, with two types of output shaft (A and T) and three types of output flange (A, T and Q).

Housing: *made of special nitrided steel to assure strength, high reliability and long life.*

Flanges: *input and output flanges made of aluminium and available in several versions.*

Shafts: *made of hardened and tempered alloy steel.*

Gears: *made of casehardened and tempered alloy steel, with ground toothing.*

Bearings: *high quality and suitably sized to assure long life and noiseless working.*

2.1 Merkmale

Die EP Serie von Planetengetrieben ist das Ergebnis des hervorragenden Verhältnis guten Preis / garantierte Präzision der Betriebseigenschaften.

Unsere Getriebe sind für überwiegende Verwendung in der folgenden Applikationen hergestellt:

- Werkzeugmaschinen
- Holzbearbeitungsmaschinen
- Transfermaschinen
- Druckmaschinen
- Automatische Verpackungsmaschinen
- Automation
- Manipulatoren
- Siebdruckmaschinen
- Linearführungen

Die EP Serie ist in 5 Größen (55, 75, 90, 120 und 155) mit 1 oder 2 Untersetzungsstufen, mit zwei Typen von Abtriebswellen (A und T) und drei Typen von Abtriebsflanschen (A, T und Q) verfügbar.

Gehäuse: aus Spezial-Nitrierstahl. Garantiert Robustheit und dauerhaft hohe Zuverlässigkeit.

Ein- u. Ausgangsflansche: aus Aluminium, in zahlreichen Varianten lieferbar.

Wellen: aus vergütetem Legierungsstahl.

Zahnräder: aus Einsatzstahl mit geschliffenen Zahnflanken.

Lager: sind hochwertig und zweckmäßig bemessen, um eine lange Lebensdauer und einen geräuscharmen Lauf zu garantieren.

2.2 Designazione

2.2 Designation

2.2 Bezeichnung

Riduttore epicicloidale Planetary gearbox Planetengetriebe	Grandezza Size Größe	Numero di stadi Steps Untersetzungsstufen	Coassiale Coaxial Koaxial	Rapporto di riduzione Ratio Untersetzungsverhältnis	Albero uscita Output shaft Durchmesser Abtriebswelle	Flangia uscita Output flange Ausgangsflansch	Albero entrata Input shaft Durchmesser Eingangswelle	Flangia in entrata Input flange Eingangsflansch
EP	55	2	C	100	A	A	AE..	P..
	55 75 90 120 155	1 2	C	3 - 100	A T	A T Q	Vedi tabelle See tables Siehe Tab.	Vedi tabelle See tables Siehe Tab.

2.3 Selezione

Per la selezione dei riduttori epicicloidali EP, seguire la procedura descritta al paragrafo 1.3.

2.3 Selection

Make the selection of the planetary gearboxes EP Series as described at paragraph 1.3

2.3 Getriebeauswahl

Die Wahl der Planetengetriebe Serie EP wird wie im Abschnitt 1.3 ausgeführt.

2.4 Gioco angolare (α_{max})

Gioco massimo [arcmin] misurato sull'albero uscita, con albero entrata bloccato applicando una coppia pari al 2% della coppia nominale.

2.4 Backlash (α_{max})

Max. backlash measured on output shaft by torque equals to 2% of the nominal torque value with input shaft blocked.

2.4 Spiel (α_{max})

Maximales Spiel [arcmin], gemessen an der Abtriebswelle bei blockierter Eingangswelle mit 2% des Nennmoments.

2.5 Carichi radiali e assiali su albero lento

Nella tabella delle prestazioni sono indicati i valori, espressi in N, dei carichi assiali e radiali ammissibili alle diverse velocità per una durata dei cuscinetti di 20.000 ore. Il carico radiale F_{R2} si considera applicato ad una distanza dalla battuta pari alla metà della lunghezza dell'albero lento. Per distanze y diverse, è possibile calcolare il nuovo carico massimo ammissibile F_{R2Y} utilizzando formula e coefficienti indicati nella tabella.

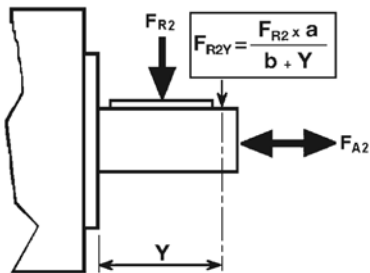

2.5 Radial and axial loads on output shaft

The table of performances shows admissible axial and radial load values expressed in N for different speeds and for a bearing life of 20.000 hours. Radial load F_{R2} calculations have been based on loads applied to the center line of the output shaft extension. For different y distance it is possible to calculate the new maximum admissible load by using formula and coefficient shown in the table.

2.5 Radial-und Axiallasten an der Abtriebswelle

Die Leistungstabelle enthält die in N ausgedrückten Werte der Axial- und Radiallasten für verschiedene Umdrehungszahlen. Diesen Werten liegt eine Lebensdauer der Lager von 20.000 Stunden zugrunde. Die Radiallast F_{R2} greift hierbei auf der Mitte der Abtriebswelle an. Greift die Radiallast an einem anderen Punkt der Abtriebswelle an, so kann man die zulässige Radiallast mit der folgenden Formel sowie den dazugehörigen Koeffizienten berechnen:

	EP 55	EP 75	EP 90	EP 120	EP 155
a	27	46	56	77	95
b	18	32	39	52	64

2.6 Lubrificazione

I riduttori EP sono forniti completi di lubrificante a vita pertanto non necessitano di manutenzione. In fase di ordine specificare la posizione di montaggio.

2.6 Lubrication

EP gearboxes are supplied filled with long-life lubricant and do not require any maintenance. When ordering it is important to specify the exact mounting position.

2.6 Schmierung

Die Planetengetriebe EP werden inklusive Dauerschmierung geliefert und sind wartungsfrei. Bei der Bestellung bitte die Einbauposition angeben.

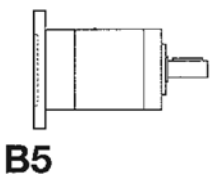

B5

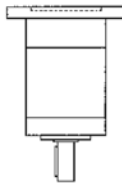

V1

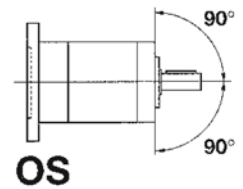
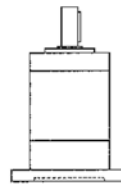

V3 OS

Simbologia e unità di misura

Symbols and unit of measure

Abkürzungen und Maßeinheiten

i	Rapporto di riduzione nominale
$n_{1\text{ nom}}$	Velocità nominale in entrata [min ⁻¹]
$n_{1\text{ max}}$	Velocità massima in entrata [min ⁻¹]
T_{2N}	Coppia nominale intermittente in uscita [Nm]
T_{2A}	Coppia massima di accelerazione in uscita [Nm]
T_{2S}	Coppia massima di emergenza in uscita [Nm]
LpA	Livello di rumorosità dB(A) a 3000 min ⁻¹
Rd	Rendimento dinamico
L_h	Durata cuscinetti [h]
F_{R2}	Carico radiale nominale in uscita [N] a 100 min ⁻¹
F_{A2}	Carico assiale in uscita [N] a 100 min ⁻¹
R_t	Rigidità torsionale [Nm / arcmin]
α_{max}	Gioco angolare standard [arcmin]
J_{min}	Momento d'inerzia minimo [kg.cm ²]
J_{max}	Momento d'inerzia massimo [kg.cm ²]

Nominal ratio
Nominal input speed [min⁻¹]
Maximum input speed [min⁻¹]
Intermittent output torque [Nm]
Maximum acceleration output torque [Nm]
Maximum emergency output torque [Nm]
Noise level dB(A) at 3000 min⁻¹
Dynamic efficiency
Bearing life [h]
Output radial load [N] at 100 min⁻¹
Output axial load [N] at 100 min⁻¹
Torsional stiffness [Nm / arcmin]
Standard backlash [arcmin]
Min. moment of inertia [kg.cm²]
Max. moment of inertia [kg.cm²]

Nenn-Untersetzungsverhältnis
Nenn-Eingangsdrehzahl [min ⁻¹]
Maximale Eingangsdrehzahl [min ⁻¹]
Nenn-Abtriebsmoment (im Aussetzbetrieb) [Nm]
Maximales Beschleunigungsmoment [Nm]
Maximale Überlast [Nm]
Geräuschpegel dB(A) bei 3000 min ⁻¹
Dynamischer Wirkungsgrad
Lebensdauer der Lager [h]
Nenn-Radiallast an der Abtriebswelle bei 100 min ⁻¹
Axiallast an der Abtriebswelle bei 100 min ⁻¹
Drehfestigkeit [Nm / arcmin]
Standard Spiel [arcmin]
Trägheitsmoment min. [kg.cm ²]
Trägheitsmoment max. [kg.cm ²]

2.7 Momento d'inerzia J
[kg·cm²]

2.7 Moment of inertia J
[kg·cm²]

2.7 Trägheitsmoment J
[kg·cm²]

EP 55								
Albero entrata / Input shaft / Antriebswelle								
Stadi Steps Stufenzahl	i	6	6.35	7	8	9	9.525	11
1	3	0.07	0.07	0.07	0.09	0.09	0.09	0.09
	4	0.06	0.06	0.06	0.08	0.08	0.08	0.08
	5	0.06	0.06	0.06	0.07	0.07	0.07	0.08
	7	0.06	0.06	0.06	0.07	0.07	0.07	0.07
	10	0.05	0.05	0.05	0.07	0.07	0.07	0.07
2	9	0.07	0.07	0.07	0.09	0.09	0.09	0.09
	12	0.07	0.07	0.07	0.09	0.09	0.09	0.09
	15	0.07	0.07	0.07	0.09	0.09	0.09	0.09
	16	0.06	0.06	0.06	0.08	0.08	0.08	0.08
	20	0.06	0.06	0.06	0.08	0.08	0.07	0.08
	25	0.06	0.06	0.06	0.07	0.07	0.07	0.08
	28	0.06	0.06	0.06	0.07	0.07	0.07	0.07
	35	0.06	0.06	0.06	0.07	0.07	0.07	0.07
	40	0.05	0.05	0.05	0.07	0.07	0.07	0.07
	50	0.05	0.05	0.05	0.07	0.07	0.07	0.07
	70	0.05	0.05	0.05	0.07	0.07	0.07	0.07
100	0.05	0.05	0.05	0.07	0.07	0.07	0.07	

EP 75											
Albero entrata / Input shaft / Antriebswelle											
Stadi Steps Stufenzahl	i	6	6.35	7	8	9	9.525	11	12	12.7	14
1	3	0.17	0.17	0.17	0.18	0.18	0.18	0.20	0.20	0.20	0.22
	4	0.12	0.12	0.12	0.13	0.13	0.13	0.14	0.15	0.14	0.16
	5	0.11	0.11	0.11	0.12	0.12	0.12	0.13	0.14	0.13	0.15
	7	0.09	0.09	0.09	0.11	0.11	0.11	0.12	0.12	0.12	0.14
	10	0.09	0.09	0.09	0.10	0.10	0.10	0.11	0.12	0.11	0.13
2	9	0.16	0.16	0.16	0.17	0.17	0.17	0.19	0.19	0.19	0.21
	12	0.16	0.16	0.16	0.17	0.17	0.17	0.18	0.18	0.18	0.20
	15	0.15	0.15	0.15	0.17	0.17	0.17	0.18	0.18	0.18	0.20
	16	0.12	0.12	0.12	0.13	0.13	0.13	0.14	0.15	0.14	0.16
	20	0.12	0.12	0.12	0.13	0.13	0.13	0.14	0.14	0.14	0.16
	25	0.10	0.10	0.10	0.12	0.12	0.12	0.13	0.13	0.13	0.15
	28	0.09	0.09	0.09	0.11	0.11	0.11	0.12	0.12	0.12	0.14
	35	0.09	0.09	0.09	0.11	0.11	0.11	0.12	0.12	0.12	0.14
	40	0.09	0.09	0.09	0.10	0.10	0.10	0.11	0.12	0.11	0.13
	50	0.09	0.09	0.09	0.10	0.10	0.10	0.11	0.12	0.11	0.13
	70	0.09	0.09	0.09	0.10	0.10	0.10	0.11	0.12	0.11	0.13
100	0.09	0.09	0.09	0.10	0.10	0.10	0.11	0.12	0.11	0.13	

I valori dei momenti d'inerzia riportati si riferiscono all'albero entrata.

The moment of inertia values refer to the input shaft.

Die Werte der Trägheitsmoment beziehen sich auf die Antriebswelle.

2.7 Momento d'inerzia J
[kg·cm²]

2.7 Moment of inertia J
[kg·cm²]

2.7 Trägheitsmoment J
[kg·cm²]

		EP 90									
		Albero entrata / Input shaft / Antriebswelle									
Stadi Steps Stufenzahl	i	9	9.525	11	12	12.7	14	15.87	16	19	
1	3	0.53	0.53	0.54	0.54	0.54	0.56	0.76	0.76	0.73	
	4	0.35	0.35	0.36	0.36	0.36	0.38	0.58	0.58	0.55	
	5	0.29	0.29	0.30	0.30	0.30	0.32	0.52	0.52	0.49	
	7	0.24	0.24	0.25	0.25	0.25	0.27	0.47	0.47	0.44	
	10	0.21	0.21	0.22	0.23	0.23	0.25	0.44	0.44	0.41	
2	9	0.53	0.53	0.54	0.55	0.55	0.56	0.76	0.76	0.73	
	12	0.51	0.51	0.52	0.53	0.53	0.55	0.74	0.74	0.71	
	15	0.51	0.51	0.52	0.52	0.52	0.54	0.74	0.74	0.70	
	16	0.34	0.34	0.35	0.35	0.35	0.37	0.57	0.57	0.54	
	20	0.34	0.34	0.35	0.35	0.35	0.37	0.57	0.57	0.53	
	25	0.28	0.28	0.29	0.29	0.29	0.31	0.51	0.51	0.48	
	28	0.24	0.23	0.24	0.25	0.25	0.27	0.46	0.46	0.43	
	35	0.23	0.23	0.24	0.25	0.25	0.27	0.46	0.46	0.43	
	40	0.21	0.21	0.22	0.23	0.23	0.24	0.44	0.44	0.41	
	50	0.21	0.21	0.22	0.23	0.22	0.24	0.44	0.44	0.41	
	70	0.21	0.21	0.22	0.23	0.22	0.24	0.44	0.44	0.41	
100	0.21	0.21	0.22	0.23	0.22	0.24	0.44	0.44	0.41		

		EP 120							
		Albero entrata / Input shaft / Antriebswelle							
Stadi Steps Stufenzahl	i	12.7	14	15.87	16	19	22	24	28
1	3	2.02	2.08	2.25	2.25	2.22	4.36	4.32	4.17
	4	1.13	1.19	1.36	1.36	1.33	3.47	3.43	3.28
	5	0.86	0.91	1.08	1.08	1.05	3.19	3.15	3.01
	7	0.62	0.68	0.85	0.85	0.82	2.96	2.92	2.77
	10	0.51	0.56	0.73	0.73	0.70	2.84	2.80	2.66
2	9	2.00	2.06	2.23	2.23	2.20	4.34	4.30	4.15
	12	1.92	1.97	2.14	2.14	2.11	4.26	4.22	4.07
	15	1.88	1.93	2.10	2.10	2.07	4.22	4.18	4.03
	16	1.07	1.13	1.30	1.30	1.27	3.41	3.37	3.22
	20	1.05	1.10	1.28	1.28	1.24	3.39	3.35	3.20
	25	0.80	0.86	1.03	1.03	0.99	3.14	3.10	2.95
	28	0.61	0.66	0.83	0.83	0.80	2.94	2.90	2.76
	35	0.60	0.65	0.82	0.82	0.79	2.94	2.90	2.75
	40	0.50	0.55	0.72	0.72	0.69	2.83	2.79	2.65
	50	0.49	0.55	0.72	0.72	0.68	2.83	2.79	2.64
	70	0.49	0.54	0.71	0.71	0.68	2.83	2.79	2.64
100	0.49	0.54	0.71	0.71	0.68	2.83	2.79	2.64	

I valori dei momenti d'inerzia riportati si riferiscono all'albero entrata.

The moment of inertia values refer to the input shaft.

Die Werte der Trägheitsmoment beziehen sich auf die Antriebswelle.

2.7 Momento d'inerzia J
[kg·cm²]

2.7 Moment of inertia J
[kg·cm²]

2.7 Trägheitsmoment J
[kg·cm²]

		EP 155								
		Albero entrata / Input shaft / Antriebswelle								
Stadi Steps Stufenzahl	i	15.87	16	19	22	24	28	32	35	38
1	3	6.97	6.97	7.01	8.24	8.21	12.21	14.05	13.92	13.59
	4	4.45	4.45	4.48	5.72	5.68	9.69	11.53	11.40	11.07
	5	3.57	3.57	3.60	4.84	4.80	8.80	10.64	10.51	10.19
	7	2.86	2.86	2.89	4.13	4.09	8.09	9.93	9.81	9.48
	10	2.49	2.49	2.52	3.76	3.72	7.73	9.57	9.44	9.11
2	9	6.84	6.84	6.87	8.11	8.07	12.07	13.91	13.79	13.46
	12	6.55	6.55	6.59	7.83	7.79	11.79	13.63	13.51	13.18
	15	6.46	6.46	6.49	7.73	7.69	11.70	13.54	13.41	13.08
	16	4.22	4.22	4.25	5.49	5.45	9.45	11.29	11.17	10.84
	20	4.16	4.16	4.19	5.43	5.40	9.40	11.24	11.11	10.78
	25	3.38	3.38	3.41	4.65	4.62	8.62	10.46	10.33	10.00
	28	2.78	2.78	2.81	4.05	4.02	8.02	9.86	9.73	9.40
	35	2.76	2.76	2.80	4.03	4.00	8.00	9.84	9.71	9.38
	40	2.45	2.45	2.48	3.72	3.69	7.69	9.53	9.40	9.07
	50	2.44	2.44	2.48	3.71	3.68	7.68	9.52	9.39	9.06
	70	2.44	2.44	2.47	3.71	3.67	7.67	9.51	9.39	9.06
100	2.43	2.43	2.46	3.70	3.67	7.67	9.51	9.38	9.05	

I valori dei momenti d'inerzia riportati si riferiscono all'albero entrata.

The moment of inertia values refer to the input shaft.

Die Werte der Trägheitsmoment beziehen sich auf die Antriebswelle.

EP 55																		Stadi Steps Stufenzahl	
Stadi Steps Stufenzahl	1					2												1	2
	i	3	4	5	7	10	9	12	15	16	20	25	28	35	40	50	70		
T _{2N}	12	14	16	12	10	14	16	16	16	16	16	16	16	16	16	14	12	n _{1nom}	4000
T _{2A}	22	24	24	22	20	24	28	28	28	28	28	28	28	28	28	24	22	n _{1max}	5000
T _{2S}	44	48	48	44	40	48	56	56	56	56	56	56	56	56	56	48	44	LpA	< 70
J	Vedi pag. 31 / See page 31 / Siehe auf Seite 31																	Lh	20000
R _t	1.0					0.9					1.0					0.9		F _{R2}	300
R _d	0.96					0.93												F _{A2}	450
Kg	0.8					1.8												α _{max}	8' 10'

2.9 Dimensioni

2.9 Dimensions

2.9 Abmessungen

Dimensioni generali e uscite / General and output dimensions / General-und Abtriebsabmessungen

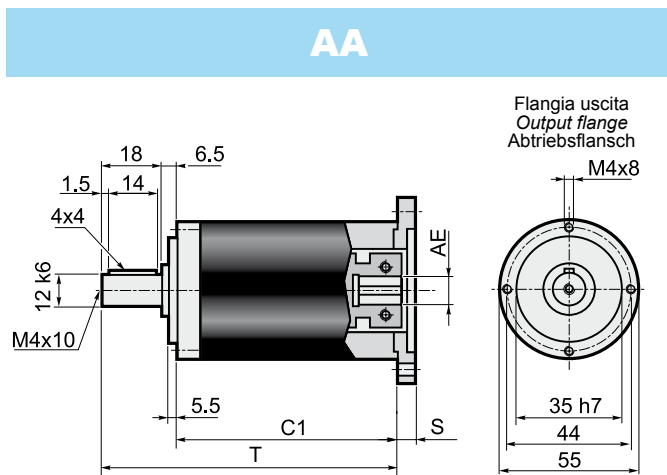

Stadi / Steps / Stufenzahl	1	2	AE= 6 - 6.35 - 7 - 8 - 9 - 9.52 - 11
C1	62.5	81.5	
T	87	106	

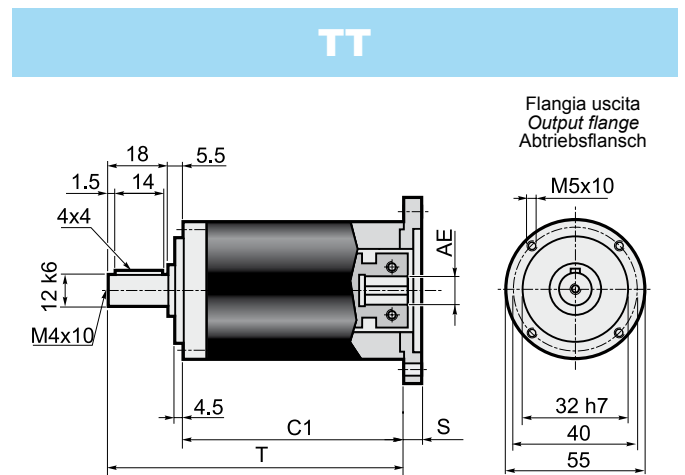

Stadi / Steps / Stufenzahl	1	2	AE= 6 - 6.35 - 7 - 8 - 9 - 9.52 - 11
C1	63.5	82.5	
T	87	106	

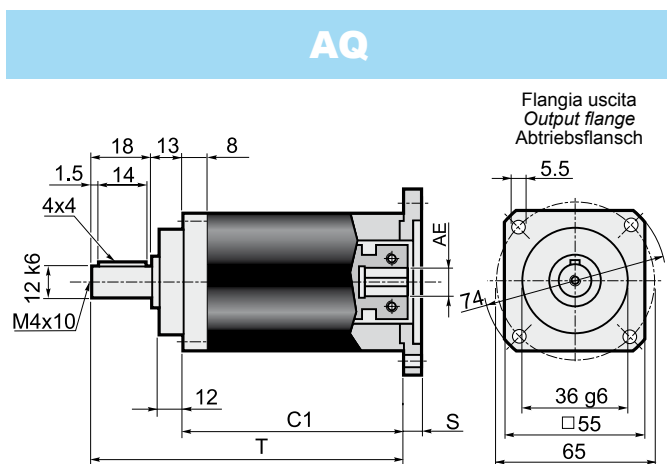

Stadi / Steps / Stufenzahl	1	2	AE= 6 - 6.35 - 7 - 8 - 9 - 9.52 - 11
C1	56	75	
T	87	106	

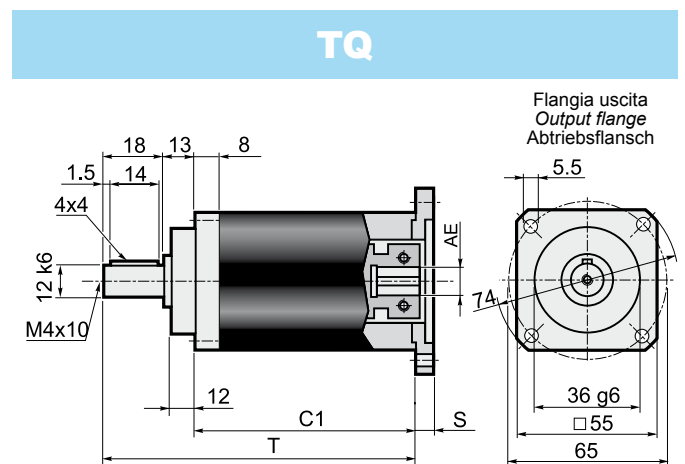

Stadi / Steps / Stufenzahl	1	2	AE= 6 - 6.35 - 7 - 8 - 9 - 9.52 - 11
C1	56	75	
T	87	106	

Dimensioni entrate / Input dimensions / Antriebsabmessungen

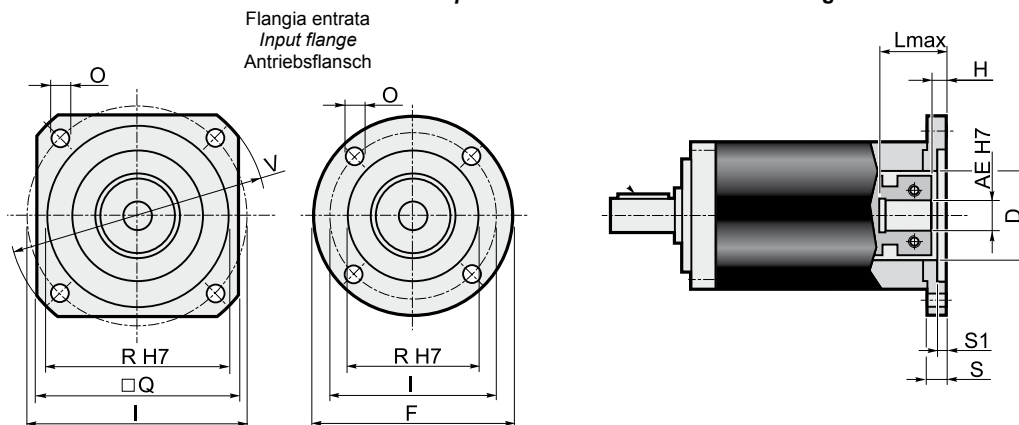

	Flange entrata / Input flange / Antriebsflansch									Albero entrata / Input shaft / Antriebswelle													
										AE													
	F	Q	V	I	R (H7)	O	S	S1	D	6	6.35	7	8	9	9.52	11							
									L _{max}	H	L _{max}	H	L _{max}	H	L _{max}	H	L _{max}	H	L _{max}	H	L _{max}	H	
P01*	60	=	=	43.82	22	4.5	10	3	22	30	7	30	7	30	7	30	7	30	7	30	7	30	7
P02*	=	60	80	66.67	38.1	5.5	10	3	32	30	7	30	7	30	7	30	7	30	7	30	7	30	7
P03*	=	60	80	63	40	5.5	10	3.5	32	30	7	30	7	30	7	30	7	30	7	30	7	30	7
P04	=	70	90	75	60	6.5	10.5	3.5	32	30.5	7.5	30.5	7.5	30.5	7.5	30.5	7.5	30.5	7.5	30.5	7.5	30.5	7.5
P05	105	=	=	85	70	6.5	10.5	3.5	32	30.5	7.5	30.5	7.5	30.5	7.5	30.5	7.5	30.5	7.5	30.5	7.5	30.5	7.5
P06	=	80	110	98.42	73.02	6	11	3.5	35	31	8	31	8	31	8	31	8	31	8	31	8	31	8
P07	=	95	120	100	80	6.5	11.5	4	32	31.5	8.5	31.5	8.5	31.5	8.5	31.5	8.5	31.5	8.5	31.5	8.5	31.5	8.5
P08	=	98	130	115	95	9	11.5	4	32	31.5	8.5	31.5	8.5	31.5	8.5	31.5	8.5	31.5	8.5	31.5	8.5	31.5	8.5
P09	=	116	160	130	110	9	12	4.5	32	32	9	32	9	32	9	32	9	32	9	32	9	32	9
P10*	60	=	=	39	26	4.5	10	3	26	30	7	30	7	30	7	30	7	30	7	30	7	30	7
P11*	60	=	=	42	32	4.5	10	3	32	30	7	30	7	30	7	30	7	30	7	30	7	30	7
P12*	65	=	=	46	32	4.5	10	3.5	32	30	7	30	7	30	7	30	7	30	7	30	7	30	7
P13*	80	=	=	65	50	5.5	10	3.5	32	30	7	30	7	30	7	30	7	30	7	30	7	30	7
P14*	60	=	=	39	20	4.5	10	2.5	20	30	7	30	7	30	7	30	7	30	7	30	7	30	7
P15	=	75	100	90	60	5.8	12	3.5	32	32	9	32	9	32	9	32	9	32	9	32	9	32	9
P16*	60	=	=	45	30	3.5	14	7	30	34	11	34	11	34	11	34	11	34	11	34	11	34	11
P17	=	60	82	70	50	4.5	16.5	8	32	36.5	13.5	36.5	13.5	36.5	13.5	36.5	13.5	36.5	13.5	36.5	13.5	36.5	13.5
P18	=	60	80	60	50	M4	10.5	3.5	32	30.5	7.5	30.5	7.5	30.5	7.5	30.5	7.5	30.5	7.5	30.5	7.5	30.5	7.5
P19*	60	=	=	36	25	4.5	10	3	25	30	7	30	7	30	7	30	7	30	7	30	7	30	7
P20	=	60	82	70	50	5.5	10.5	3.5	32	30.5	7.5	30.5	7.5	30.5	7.5	30.5	7.5	30.5	7.5	30.5	7.5	30.5	7.5
P21*	60	=	=	46	30	4.5	10	3	30	30	7	30	7	30	7	30	7	30	7	30	7	30	7
P22	=	60	80	70.71	36	4.5	10	2	32	30	7	30	7	30	7	30	7	30	7	30	7	30	7
P23	=	62	85	70	50	5.5	15.5	3.5	32	35.5	12.5	35.5	12.5	35.5	12.5	35.5	12.5	35.5	12.5	35.5	12.5	35.5	12.5
P24	=	75	100	90	70	5.8	12	3.5	32	32	9	32	9	32	9	32	9	32	9	32	9	32	9
P25	=	70	95	85	55	5.8	12	3.5	32	32	9	32	9	32	9	32	9	32	9	32	9	32	9
P26*	=	60	80	65.5	34	5.5	10	3.5	33	30	7	30	7	30	7	30	7	30	7	30	7	30	7
P27	=	80	110	95	50	6.5	12	3.5	32	32	9	32	9	32	9	32	9	32	9	32	9	32	9
P28	=	60	80	66.67	38.1	M4	9	2.5	32	29	6	29	6	29	6	29	6	29	6	29	6	29	6
P29	60	=	=	45	30	M3	11	4	32	31	8	31	8	31	8	31	8	31	8	31	8	31	8
P30	=	70	95	85	60	5.8	12	3.5	32	32	9	32	9	32	9	32	9	32	9	32	9	32	9
P31	=	62	85	70	50	M4	11	3.5	32	31	8	31	8	31	8	31	8	31	8	31	8	31	8
P32	=	60	80	65	40	M5	10	3.5	32	30	7	30	7	30	7	30	7	30	7	30	7	30	7
P33	=	85	115	99	60	5.5	11	3.5	35	31	8	31	8	31	8	31	8	31	8	31	8	31	8
P34	=	65	87	73.54	40	M4	10	3.5	32	30	7	30	7	30	7	30	7	30	7	30	7	30	7
P35	=	60	80	70.71	36	M4	14	2	32	34	11	34	11	34	11	34	11	34	11	34	11	34	11
P36	=	85	115	98.42	73.02	6	15	3.5	35	35	12	35	12	35	12	35	12	35	12	35	12	35	12
P38	60	=	=	48	30	M3	11	7	32	31	8	31	8	31	8	31	8	31	8	31	8	31	8
P41*	68	=	=	50	30	5.5	10	10	30	30	7	30	7	30	7	30	7	30	7	30	7	30	7

* Per assemblare il motore è necessario smontare la flangia dal riduttore (vedere schema di montaggio 2 a pag. 45).

* Before the mounting of the motor it is necessary to remove the flange from the gearbox (see structural arrangement 2 at the top of the page 45).

* Vor dem Einbauen des Motors soll die Getriebeflange abmontiert werden (siehe Bauanleitung 2 auf Seite 45).

EP 75																		Stadi Steps Stufenzahl	
Stadi Steps Stufenzahl	1					2												1	2
	i	3	4	5	7	10	9	12	15	16	20	25	28	35	40	50	70		
T _{2N}	22	28	32	28	20	26	32	36	36	36	36	36	36	36	36	30	22	n _{1nom}	4000
T _{2A}	40	45	50	45	40	50	60	60	60	60	60	60	60	60	60	50	45	n _{1max}	5000
T _{2S}	80	90	100	90	80	100	120	120	120	120	120	120	120	120	120	100	90	LpA	< 70
J	Vedi pag. 31 / See page 31 / Siehe auf Seite 31																	Lh	20000
R _t	3.5					3.0					3.5					3.0		F _{R2}	1800
R _d	0.96					0.93												F _{A2}	1400
Kg	1.4					2.0												α _{max}	8' 10'

2.9 Dimensioni

2.9 Dimensions

2.9 Abmessungen

Dimensioni generali e uscite / General and output dimensions / General-und Abtriebsabmessungen

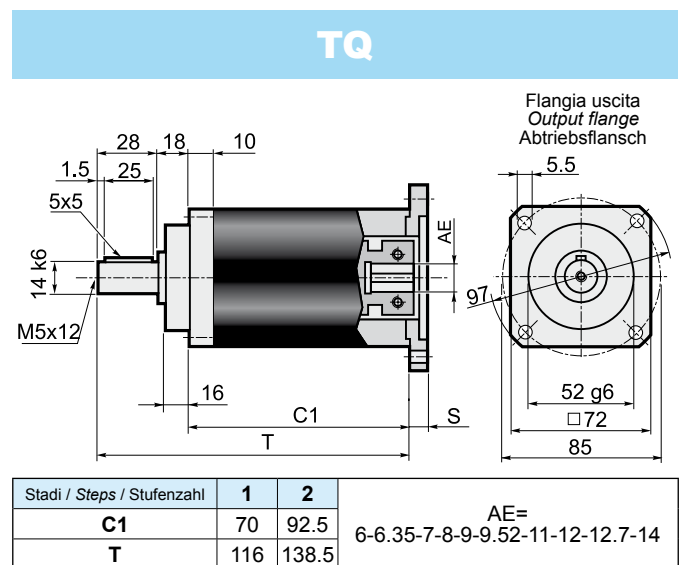
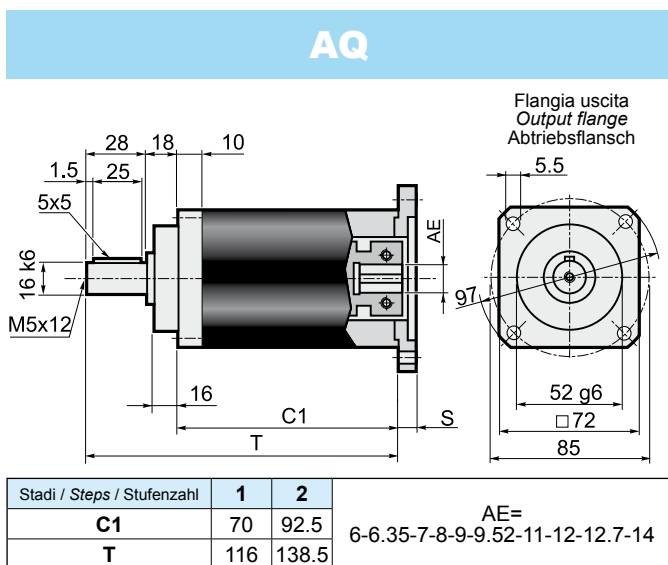
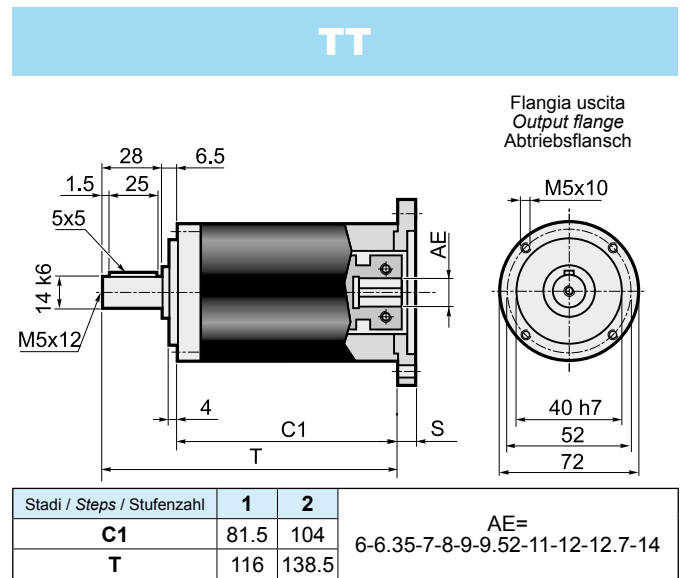
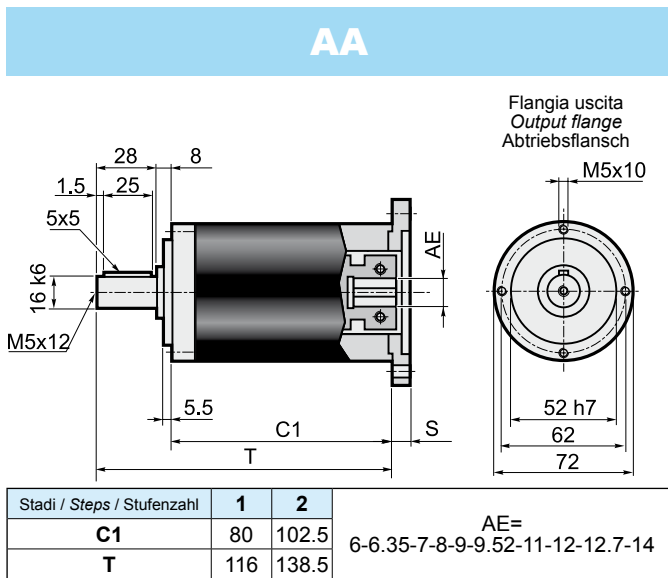

Dimensioni entrate / Input dimensions / Antriebsabmessungen

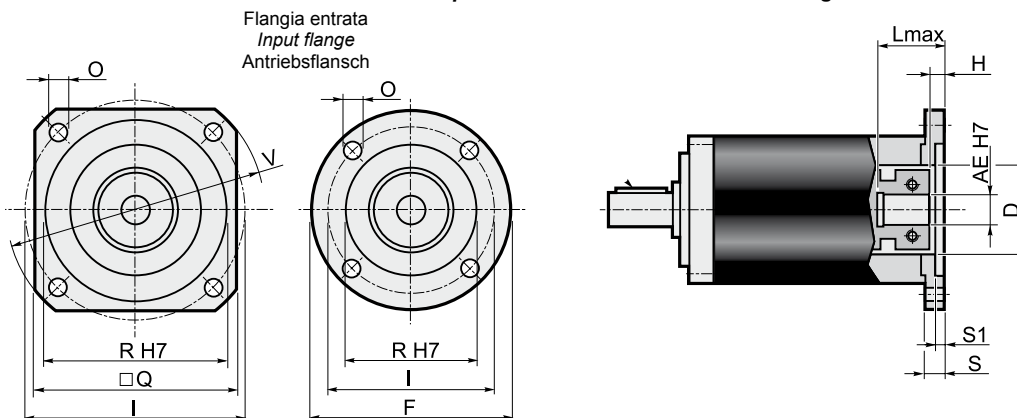

Flange entrata / Input flange / Antriebsflansch										Albero entrata / Input shaft / Antriebswelle																			
										AE																			
										6		6.35		7		8		9		9.52		11		12		12.7		14	
F	Q	V	I	R (H7)	O	S	S1	D	L _{max}	H	L _{max}	H	L _{max}	H	L _{max}	H	L _{max}	H	L _{max}	H	L _{max}	H	L _{max}	H	L _{max}	H			
P01*	60	=	=	43.82	22	4.5	10	3	22	35	4.5	35	4.5	35	4.5	26	6.5	26	6.5	35	6.5	26	6.5	35	6.5	35	6.5	35	6.5
P02*	=	60	80	66.67	38.1	5.5	10	3	32	35	4.5	35	4.5	35	4.5	26	6.5	26	6.5	35	6.5	26	6.5	35	6.5	35	6.5	35	6.5
P03*	=	60	80	63	40	5.5	10	3.5	32	35	4.5	35	4.5	35	4.5	26	6.5	26	6.5	35	6.5	26	6.5	35	6.5	35	6.5	35	6.5
P04	=	70	90	75	60	6.5	10.5	3.5	32	35.5	5	35.5	5	35.5	5	26.5	7	26.5	7	35.5	7	26.5	7	35.5	7	35.5	7	35.5	7
P05	105	=	=	85	70	6.5	10.5	3.5	32	35.5	5	35.5	5	35.5	5	26.5	7	26.5	7	35.5	7	26.5	7	35.5	7	35.5	7	35.5	7
P06	=	80	110	98.42	73.02	6	11	3.5	35	36	5.5	36	5.5	36	5.5	27	7.5	27	7.5	36	7.5	27	7.5	36	7.5	36	7.5	36	7.5
P07	=	95	120	100	80	6.5	11.5	4	32	36.5	6	36.5	6	36.5	6	27.5	8	27.5	8	36.5	8	27.5	8	36.5	8	36.5	8	36.5	8
P08	=	98	130	115	95	9	11.5	4	32	36.5	6	36.5	6	36.5	6	27.5	8	27.5	8	36.5	8	27.5	8	36.5	8	36.5	8	36.5	8
P09	=	116	160	130	110	9	12	4.5	32	37	6.5	37	6.5	37	6.5	28	8.5	28	8.5	37	8.5	28	8.5	37	8.5	37	8.5	37	8.5
P10*	60	=	=	39	26	4.5	10	3	26	35	4.5	35	4.5	35	4.5	26	6.5	26	6.5	35	6.5	26	6.5	35	6.5	35	6.5	35	6.5
P11*	60	=	=	42	32	4.5	10	3	32	35	4.5	35	4.5	35	4.5	26	6.5	26	6.5	35	6.5	26	6.5	35	6.5	35	6.5	35	6.5
P12*	65	=	=	46	32	4.5	10	3.5	32	35	4.5	35	4.5	35	4.5	26	6.5	26	6.5	35	6.5	26	6.5	35	6.5	35	6.5	35	6.5
P13*	80	=	=	65	50	5.5	10	3.5	32	35	4.5	35	4.5	35	4.5	26	6.5	26	6.5	35	6.5	26	6.5	35	6.5	35	6.5	35	6.5
P14*	60	=	=	39	20	4.5	10	2.5	20	35	4.5	35	4.5	35	4.5	26	6.5	26	6.5	35	6.5	26	6.5	35	6.5	35	6.5	35	6.5
P15	=	75	100	90	60	5.8	12	3.5	32	37	6.5	37	6.5	37	6.5	28	8.5	28	8.5	37	8.5	28	8.5	37	8.5	37	8.5	37	8.5
P16*	60	=	=	45	30	3.5	14	7	30	39	8.5	39	8.5	39	8.5	30	10.5	30	10.5	39	10.5	30	10.5	39	10.5	39	10.5	39	10.5
P17	=	60	82	70	50	4.5	16.5	8	32	41.5	11	41.5	11	41.5	11	32.5	13	32.5	13	41.5	13	32.5	13	41.5	13	41.5	13	41.5	13
P18	=	60	80	60	50	M4	10.5	3.5	32	35.5	5	35.5	5	35.5	5	26.5	7	26.5	7	35.5	7	26.5	7	35.5	7	35.5	7	35.5	7
P19*	60	=	=	36	25	4.5	10	3	25	35	4.5	35	4.5	35	4.5	26	6.5	26	6.5	35	6.5	26	6.5	35	6.5	35	6.5	35	6.5
P20	=	60	82	70	50	5.5	10.5	3.5	32	35.5	5	35.5	5	35.5	5	26.5	7	26.5	7	35.5	7	26.5	7	35.5	7	35.5	7	35.5	7
P21*	60	=	=	46	30	4.5	10	3	30	35	4.5	35	4.5	35	4.5	26	6.5	26	6.5	35	6.5	26	6.5	35	6.5	35	6.5	35	6.5
P22	=	60	80	70.71	36	4.5	10	2	32	35	4.5	35	4.5	35	4.5	26	6.5	26	6.5	35	6.5	26	6.5	35	6.5	35	6.5	35	6.5
P23	=	62	85	70	50	5.5	15.5	3.5	32	40.5	10	40.5	10	40.5	10	31.5	12	31.5	12	40.5	12	31.5	12	40.5	12	40.5	12	40.5	12
P24	=	75	100	90	70	5.8	12	3.5	32	37	6.5	37	6.5	37	6.5	28	8.5	28	8.5	37	8.5	28	8.5	37	8.5	37	8.5	37	8.5
P25	=	70	95	85	55	5.8	12	3.5	32	37	6.5	37	6.5	37	6.5	28	8.5	28	8.5	37	8.5	28	8.5	37	8.5	37	8.5	37	8.5
P26*	=	60	80	65.5	34	5.5	10	3.5	33	35	4.5	35	4.5	35	4.5	26	6.5	26	6.5	35	6.5	26	6.5	35	6.5	35	6.5	35	6.5
P27	=	80	110	95	50	6.5	12	3.5	32	37	6.5	37	6.5	37	6.5	28	8.5	28	8.5	37	8.5	28	8.5	37	8.5	37	8.5	37	8.5
P28	=	60	80	66.67	38.1	M4	9	2.5	32	34	3.5	34	3.5	34	3.5	25	5.5	25	5.5	34	5.5	25	5.5	34	5.5	34	5.5	34	5.5
P29	60	=	=	45	30	M3	11	4	32	36	5.5	36	5.5	36	5.5	27	7.5	27	7.5	36	7.5	27	7.5	36	7.5	36	7.5	36	7.5
P30	=	70	95	85	60	5.8	12	3.5	32	37	6.5	37	6.5	37	6.5	28	8.5	28	8.5	37	8.5	28	8.5	37	8.5	37	8.5	37	8.5
P31	=	62	85	70	50	M4	11	3.5	32	36	5.5	36	5.5	36	5.5	27	7.5	27	7.5	36	7.5	27	7.5	36	7.5	36	7.5	36	7.5
P32	=	60	80	65	40	M5	10	3.5	32	35	4.5	35	4.5	35	4.5	26	6.5	26	6.5	35	6.5	26	6.5	35	6.5	35	6.5	35	6.5
P33	=	85	115	99	60	5.5	11	3.5	32	36	5.5	36	5.5	36	5.5	27	7.5	27	7.5	36	7.5	27	7.5	36	7.5	36	7.5	36	7.5
P34	=	65	87	73.54	40	M4	10	3.5	32	35	4.5	35	4.5	35	4.5	26	6.5	26	6.5	35	6.5	26	6.5	35	6.5	35	6.5	35	6.5
P35	=	60	80	70.71	36	M4	14	2	32	39	8.5	39	8.5	39	8.5	30	10.5	30	10.5	39	10.5	30	10.5	39	10.5	39	10.5	39	10.5
P36	=	85	115	98.42	73.02	6	15	3.5	35	40	9.5	40	9.5	40	9.5	35	11.5	31	11.5	40	11.5	35	11.5	40	11.5	40	11.5	40	11.5
P38	60	=	=	48	30	M3	11	7	32	36	5.5	36	5.5	36	5.5	27	7.5	27	7.5	36	7.5	27	7.5	36	7.5	36	7.5	36	7.5
P41*	68	=	=	50	30	5.5	10	10	30	35	4.5	35	4.5	35	4.5	26	6.5	26	6.5	35	6.5	26	6.5	35	6.5	35	6.5	35	6.5

* Per assemblare il motore è necessario smontare la flangia dal riduttore (vedere schema di montaggio 2 a pag. 45).

* Before the mounting of the motor it is necessary to remove the flange from the gearbox (see structural arrangement 2 at the top of the page 45).

* Vor dem Einbauen des Motors soll die Getriebeflang abmontiert werden (siehe Bauanleitung 2 auf Seite 45).

EP 90																		Stadi Steps Stufenzahl		
Stadi Steps Stufenzahl	1					2												1	2	
	i	3	4	5	7	10	9	12	15	16	20	25	28	35	40	50	70			100
T_{2N}	50	55	60	55	50	65	70	75	75	75	75	75	75	75	75	65	55	n_{1nom}	4000	
T_{2A}	80	90	100	90	80	100	110	120	120	120	120	120	120	120	120	100	90	n_{1max}	5000	
T_{2S}	160	180	200	180	160	200	220	240	240	240	240	240	240	240	240	200	180	LpA	< 70	
J	Vedi pag. 32 / See page 32 / Siehe auf Seite 32																	Lh	20000	
R_t	9.0					7.5					9.0					7.5			F_{R2}	2600
R_d	0.96					0.93												F_{A2}	2000	
Kg	2.8					3.7												α_{max}	8' 10'	

2.9 Dimensioni

2.9 Dimensions

2.9 Abmessungen

Dimensioni generali e uscite / General and output dimensions / General-und Abtriebsabmessungen

AA

Flangia uscita
Output flange
Abtriebsflansch

Stadi / Steps / Stufenzahl	1	2	AE= 9-9.52-11-12-12.7-14-15.87-16-19
C1	98	127	
T	144	173	

TT

Flangia uscita
Output flange
Abtriebsflansch

Stadi / Steps / Stufenzahl	1	2	AE= 9-9.52-11-12-12.7-14-15.87-16-19
C1	101	130	
T	144	173	

AQ

Flangia uscita
Output flange
Abtriebsflansch

Stadi / Steps / Stufenzahl	1	2	AE= 9-9.52-11-12-12.7-14-15.87-16-19
C1	88	117	
T	144	173	

TQ

Flangia uscita
Output flange
Abtriebsflansch

Stadi / Steps / Stufenzahl	1	2	AE= 9-9.52-11-12-12.7-14-15.87-16-19
C1	88	117	
T	144	173	

Dimensioni entrate / Input dimensions / Antriebsabmessungen

Flangia entrata
Input flange
Antriebsflansch

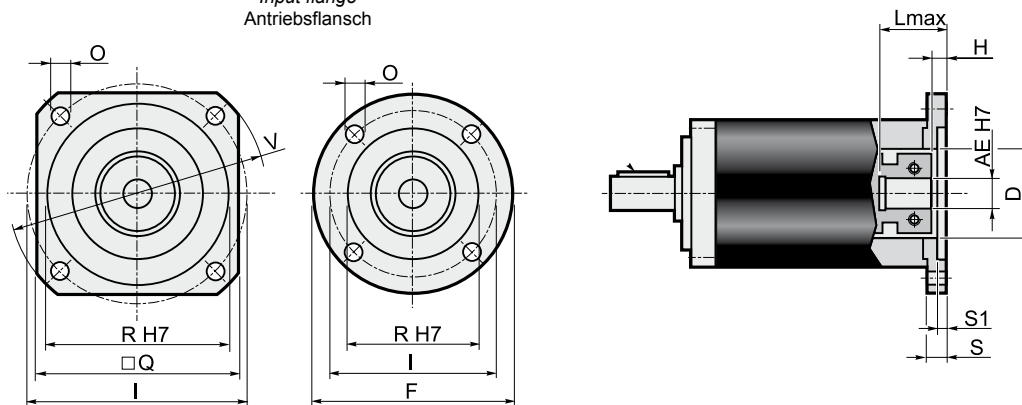

Flange entrata / Input flange / Antriebsflansch										Albero entrata / Input shaft / Antriebswelle																	
										AE																	
										9		9.525		11		12		12.7		14		15.87		16		19	
F	Q	V	I	R (H7)	O	S	S1	D	L max	H	L max	H	L max	H	L max	H	L max	H	L max	H	L max	H	L max	H			
P01*	80	=	=	66.67	38.1	5.5	12	3	38.1	44	6.5	44	9	29	9	44	9	44	9	44	9	44	9	44	9	44	9
P02	=	106.5	140	125.72	55.52	7	11	3	45	43	5.5	43	8	28	8	43	8	43	8	43	8	43	8	43	8	43	8
P03*	=	80	90	75	60	5.5	12	3.5	45	44	6.5	44	9	29	9	44	9	44	9	44	9	44	9	44	9	44	9
P04*	105	=	=	85	70	6.5	12	3.5	45	44	6.5	44	9	29	9	44	9	44	9	44	9	44	9	44	9	44	9
P05	=	82.5	110	98.425	73.02	6.5	12	3	45	44	6.5	44	9	29	9	44	9	44	9	44	9	44	9	44	9	44	9
P06	=	90	120	100	80	6.5	13	4	45	45	7.5	45	10	30	10	45	10	45	10	45	10	45	10	45	10	45	10
P07	=	100	135	115	95	8.5	13	4.5	45	45	7.5	45	10	30	10	45	10	45	10	45	10	45	10	45	10	45	10
P08	=	116	160	130	110	9	13	4.5	45	45	7.5	45	10	30	10	45	10	45	10	45	10	45	10	45	10	45	10
P09*	80	=	=	39	26	4.5	12	4	26	44	6.5	44	9	29	9	44	9	44	9	44	9	44	9	44	9	44	9
P10*	80	=	=	65	50	5.5	12	3.5	45	44	6.5	44	9	29	9	44	9	44	9	44	9	44	9	44	9	44	9
P11	=	150	182	166	115	9	32	11	50x14	64	26.5	64	29	49	29	64	29	64	29	64	29	64	29	64	29	64	29
P12*	=	80	105	90	70	6.5	12	3.5	32	44	6.5	44	9	29	9	44	9	44	9	44	9	44	9	44	9	44	9
P14*	105	=	=	90	70	6	19	9	32	51	13.5	51	16	36	16	51	16	51	16	51	16	51	16	51	16	51	16
P15*	80	=	=	70	50	4.5	17	8	45	49	11.5	49	14	34	14	49	14	49	14	49	14	49	14	49	14	49	14
P16	=	142	190	165	130	11	13	4.5	45	45	7.5	45	10	30	10	45	10	45	10	45	10	45	10	45	10	45	10
P17*	80	=	=	63	40	5.5	12	3.5	40	44	6.5	44	9	29	9	44	9	44	9	44	9	44	9	44	9	44	9
P18	=	130	170	145	110	M8	31	7	32	63	25.5	63	28	48	28	63	28	63	28	63	28	63	28	63	28	63	28
P19*	=	80	105	90	60	6.5	12	3.5	32	44	6.5	44	9	29	9	44	9	44	9	44	9	44	9	44	9	44	9
P20*	=	80	105	85	55	5.5	12	3.5	36	44	6.5	44	9	29	9	44	9	44	9	44	9	44	9	44	9	44	9
P21	=	80	110	95	50	M6	12	3.5	45	44	6.5	44	9	29	9	44	9	44	9	44	9	44	9	44	9	44	9
P22	80	=	=	70	50	M4	12	4	45	44	6.5	44	9	29	9	44	9	44	9	44	9	44	9	44	9	44	9
P23	=	80	90	75	60	M5	12	3.5	45	44	6.5	44	9	29	9	44	9	44	9	44	9	44	9	44	9	44	9
P24	80	=	=	46	30	M4	12	4	30	44	6.5	44	9	29	9	44	9	44	9	44	9	44	9	44	9	44	9
P26	80	=	=	65	40	M5	12	3.5	40	44	6.5	44	9	29	9	44	9	44	9	44	9	44	9	44	9	44	9
P27	=	80	105	82.02	36.8	M6	14	10	36.8	46	8.5	46	11	31	11	46	11	46	11	46	11	46	11	46	11	46	11
P28	=	90	120	100	80	6.5	28	4	45	60	22.5	60	25	45	25	60	25	60	25	60	25	60	25	60	25	60	25
P29*	80	=	=	66.67	50	5.5	12	3	45	44	6.5	44	9	29	9	44	9	44	9	44	9	44	9	44	9	44	9
P30	=	115	155	130	80	9	13	4	45	45	7.5	45	10	30	10	45	10	45	10	45	10	45	10	45	10	45	10
P31*	=	80	105	56	44	M6	14	10	36.8	46	8.5	46	11	31	11	46	11	46	11	46	11	46	11	46	11	46	11
P32	=	80	105	90	70	M6	12	3.5	32	44	6.5	44	9	29	9	44	9	44	9	44	9	44	9	44	9	44	9
P33	=	130	165	145	110	9	13	4.5	45	45	7.5	45	10	30	10	45	10	45	10	45	10	45	10	45	10	45	10
P34	=	90	120	100	80	M6	19	5	45	51	13.5	51	16	36	16	51	16	51	16	51	16	51	16	51	16	51	16
P36	=	100	135	115	95	M8	25	4.5	45	57	19.5	57	22	42	22	57	22	57	22	57	22	57	22	57	22	57	22
P37	=	85	115	98.99	60	M6	12	3.5	32	44	6.5	44	9	29	9	44	9	44	9	44	9	44	9	44	9	44	9
P38	80	=	=	70	50	M5	12	4	45	44	6.5	44	9	29	9	44	9	44	9	44	9	44	9	44	9	44	9
P39	=	90	120	100	80	6.5	13	4.5	45	45	7.5	45	10	30	10	45	10	45	10	45	10	45	10	45	10	45	10
P40	=	80	90	75	60	M6	12	3.5	45	44	6.5	44	9	29	9	44	9	44	9	44	9	44	9	44	9	44	9

* Per assemblare il motore è necessario smontare la flangia dal riduttore (vedere schema di montaggio 2 a pag. 45).

* Before the mounting of the motor it is necessary to remove the flange from the gearbox (see structural arrangement 2 at the top of the page 45).

* Vor dem Einbauen des Motors soll die Getriebeflange abmontiert werden (siehe Bauanleitung 2 auf Seite 45).

EP 120																		Stadi Steps Stufenzahl	
Stadi Steps Stufenzahl	1					2												1	2
i	3	4	5	7	10	9	12	15	16	20	25	28	35	40	50	70	100	1	2
T _{2N}	120	150	180	150	100	150	180	220	220	220	220	220	220	220	220	170	110	n _{1nom}	3000
T _{2A}	190	240	290	220	180	240	290	350	350	350	350	350	350	350	350	270	200	n _{1max}	4000
T _{2S}	400	500	600	460	380	500	600	700	700	700	700	700	700	700	700	540	400	LpA	< 70
J	Vedi pag. 32 / See page 32 / Siehe auf Seite 32																	Lh	20000
R _t	32			28		32		30						28			F _{R2}	4500	
R _d	0.96					0.93												F _{A2}	4000
Kg	7.5					8.0												α _{max}	8' 10'

2.9 Dimensioni

2.9 Dimensions

2.9 Abmessungen

Dimensioni generali e uscite / General and output dimensions / General-und Abtriebsabmessungen

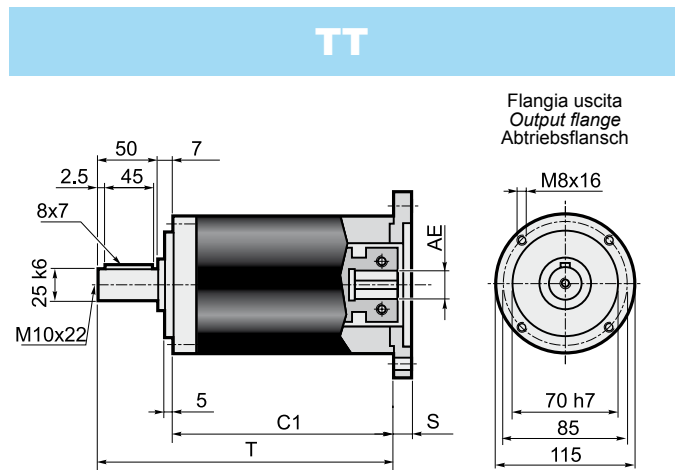
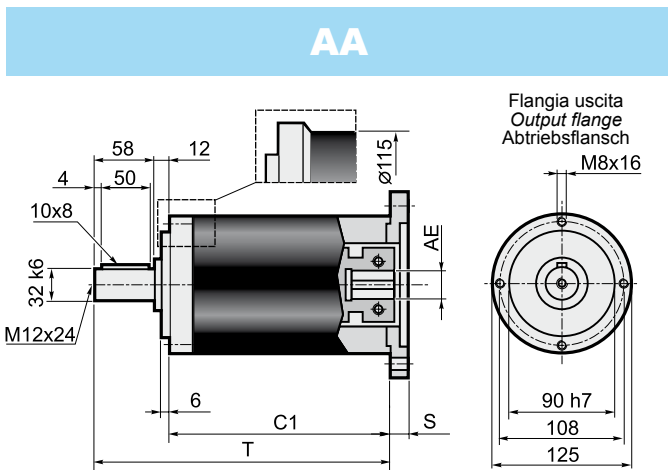

Stadi / Steps / Stufenzahl	1	2	AE= 12.7-14-15.87-16-19
C1	115.8	148.4	
T	185.8	218.4	
Stadi / Steps / Stufenzahl	1	2	AE= 22-24-25-28
C1	134.8	167.4	
T	185.8	218.4	

Stadi / Steps / Stufenzahl	1	2	AE= 12.7-14-15.87-16-19
C1	120.8	153.4	
T	177.8	210.4	
Stadi / Steps / Stufenzahl	1	2	AE= 22-24-25-28
C1	139.8	172.4	
T	196.8	229.4	

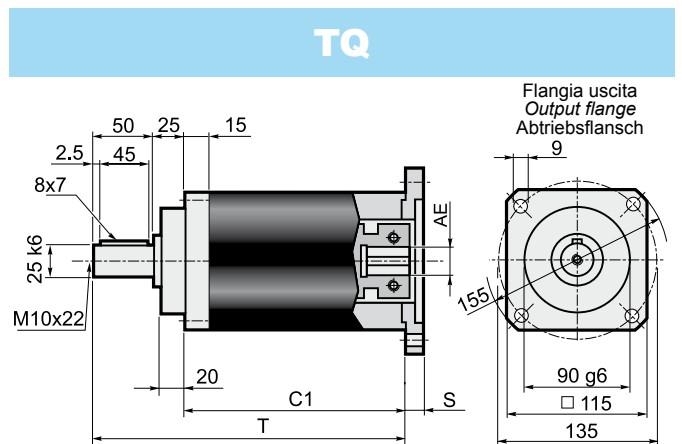
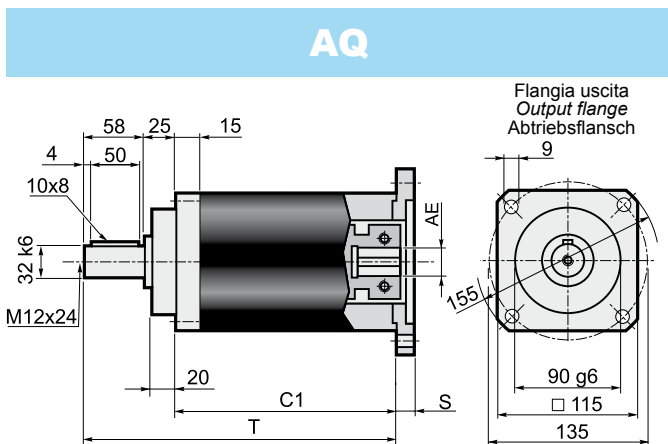

Stadi / Steps / Stufenzahl	1	2	AE= 12.7-14-15.87-16-19
C1	102.8	135.4	
T	185.8	218.4	
Stadi / Steps / Stufenzahl	1	2	AE= 22-24-25-28
C1	121.8	154.4	
T	204.8	237.4	

Stadi / Steps / Stufenzahl	1	2	AE= 12.7-14-15.87-16-19
C1	102.8	135.4	
T	177.8	210.4	
Stadi / Steps / Stufenzahl	1	2	AE= 22-24-25-28
C1	121.8	154.4	
T	196.8	229.4	

Dimensioni entrate / Input dimensions / Antriebsabmessungen

Flangia entrata
Input flange
Antriebsflansch

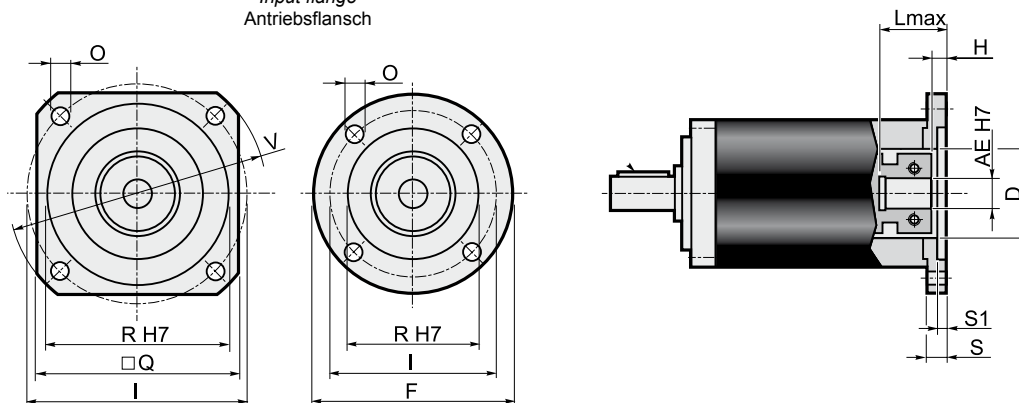

Flange entrata / Input flange / Antriebsflansch										Albero entrata / Input shaft / Antriebswelle																	
										AE																	
										12.7		14		15.87		16		19		22		24		25		28	
F	Q	V	I	R (H7)	O	S	S1	D	L _{max}	H	L _{max}	H	L _{max}	H	L _{max}	H	L _{max}	H	L _{max}	H	L _{max}	H	L _{max}	H			
P01*	=	115	140	125.72	55.52	6.5	13	3	55.52	43	6	35	6	43	6	43	6	43	6	62	6	62	6	62	6	62	6
P02*	115	=	=	75	60	5.5	13	3.5	60	43	6	35	6	43	6	43	6	43	6	62	6	62	6	62	6	62	6
P03*	115	=	=	85	70	6.5	13	3.5	60	43	6	35	6	43	6	43	6	43	6	62	6	62	6	62	6	62	6
P04*	115	=	=	98.42	73.02	6.5	13	3	60	43	6	35	6	43	6	43	6	43	6	62	6	62	6	62	6	62	6
P05*	120	=	=	100	80	6.5	13	4	60	43	6	35	6	43	6	43	6	43	6	62	6	62	6	62	6	62	6
P06*	=	115	140	115	95	9	13	4.5	60	43	6	35	6	43	6	43	6	43	6	62	6	62	6	62	6	62	6
P07	=	115	160	130	110	8.5	13	4.5	60	43	6	35	6	43	6	43	6	43	6	62	6	62	6	62	6	62	6
P08	=	142	190	165	130	11	13	4.5	60	43	6	35	6	43	6	43	6	43	6	62	6	62	6	62	6	62	6
P09	=	192	250	215	180	13	14	4.5	60	44	7	36	7	44	7	44	7	44	7	63	7	63	7	63	7	63	7
P10*	115	=	=	65	50	6.5	13	3.5	50	43	6	35	6	43	6	43	6	43	6	62	6	62	6	62	6	62	6
P11	=	130	170	145	110	M 8	31	7	60	61	24	53	24	61	24	61	24	61	24	80	24	80	24	80	24	80	24
P12	=	130	170	145	110	M 8	17	7	60	47	10	39	10	47	10	47	10	47	10	66	10	66	10	66	10	66	10
P13	=	115	160	130	110	M 8	13	4.5	60	43	6	35	6	43	6	43	6	43	6	62	6	62	6	62	6	62	6
P14*	115	=	=	70	50	6.5	13	3.5	50	43	6	35	6	43	6	43	6	43	6	62	6	62	6	62	6	62	6
P15	115	=	=	90	70	M5	11	3.5	60	41	4	33	4	41	4	41	4	41	4	60	4	60	4	60	4	60	4
P17*	115	=	=	90	70	6.5	13	3.5	60	43	6	35	6	43	6	43	6	43	6	62	6	62	6	62	6	62	6
P18	=	115	155	130	95	8.5	13	4.5	60	43	6	35	6	43	6	43	6	43	6	62	6	62	6	62	6	62	6
P19*	115	=	=	95	50	6.5	13	3.5	50	43	6	35	6	43	6	43	6	43	6	62	6	62	6	62	6	62	6
P20	115	=	=	99	60	M6	13	4	60	43	6	35	6	43	6	43	6	43	6	62	6	62	6	62	6	62	6
P21*	130	=	=	106	82.5	12.5	26.3	15	60	56.5	19.5	48.5	19.5	56.5	19.5	56.5	19.5	56.5	19.5	75.5	19.5	75.5	19.5	75.5	19.5	75.5	19.5
P22	=	144	190	165	110	11	15	4.5	60	45	8	37	8	45	8	45	8	45	8	64	8	64	8	64	8	64	8
P23*	115	=	=	63	40	5.5	11	3.5	40	41	4	33	4	41	4	41	4	41	4	60	4	60	4	60	4	60	4
P24	120	=	=	100	80	M6	18	7	60	48	11	40	11	48	11	48	11	48	11	67	11	67	11	67	11	67	11
P25	=	115	155	115	95	M8	27	4.5	60	57	20	49	20	57	20	57	20	57	20	76	20	76	20	76	20	76	20
P26	=	115	155	131.95	55.52	M8	27	4.5	60	57	20	49	20	57	20	57	20	57	20	76	20	76	20	76	20	76	20

* Per assemblare il motore è necessario smontare la flangia dal riduttore (vedere schema di montaggio 2 a pag. 45).

* Before the mounting of the motor it is necessary to remove the flange from the gearbox (see structural arrangement 2 at the top of the page 45).

* Vor dem Einbauen des Motors soll die Getriebeflang abmontiert werden (siehe Bauanleitung 2 auf Seite 45).

2.8 Dati tecnici

2.8 Technical data

2.8 Technische Daten

EP 155																		Stadi Steps Stufenzahl	
Stadi Steps Stufenzahl	1					2													
i	3	4	5	7	10	9	12	15	16	20	25	28	35	40	50	70	100	1	2
T _{2N}	240	320	380	300	220	320	400	500	500	500	500	500	500	500	500	350	250	n _{1nom}	3000
T _{2A}	420	540	600	480	400	480	600	750	750	750	750	750	750	750	750	560	460	n _{1max}	4000
T _{2S}	880	1140	1260	1000	850	1000	1250	1500	1500	1500	1500	1500	1500	1500	1500	1120	920	LpA	< 70
J	Vedi pag. 33 / See page 33 / Siehe auf Seite 33																	Lh	20000
R _t	60				50	60											50	F _{R2} (AA)	6500
																		F _{R2} (TT)	5300
R _d	0.96					0.93												F _{A2} (AA)	3250
																		F _{A2} (TT)	2650
Kg	10.9					15.7												α _{max}	8' 10'

2.9 Dimensioni

2.9 Dimensions

2.9 Abmessungen

Dimensioni generali e uscite / General and output dimensions / General-und Abtriebsabmessungen

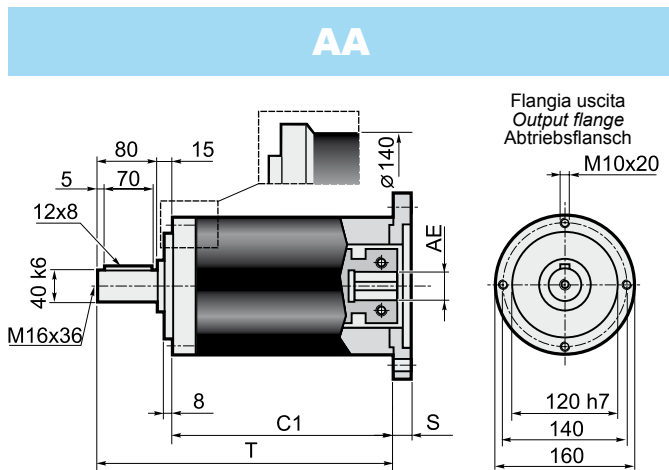

Stadi / Steps / Stufenzahl	1	2	AE= 15.87-16-19-22-24
C1	156	197.5	
T	251	292.5	
Stadi / Steps / Stufenzahl	1	2	AE= 28-32-35-38
C1	181	222.5	
T	276	317.5	

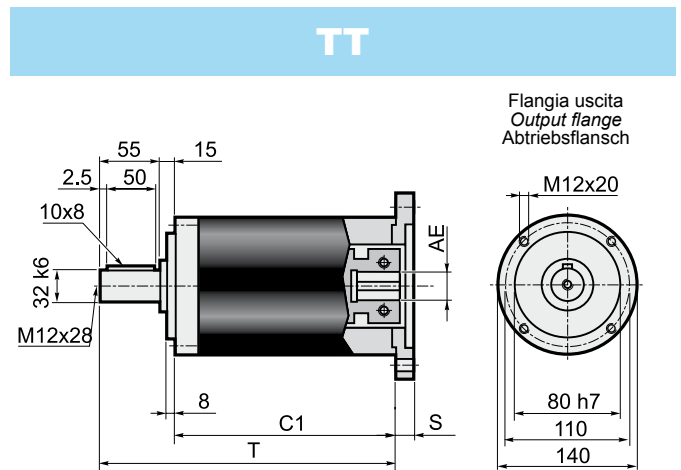

Stadi / Steps / Stufenzahl	1	2	AE= 15.87-16-19-22-24
C1	156	197.5	
T	226	267.5	
Stadi / Steps / Stufenzahl	1	2	AE= 28-32-35-38
C1	181	222.5	
T	251	292.5	

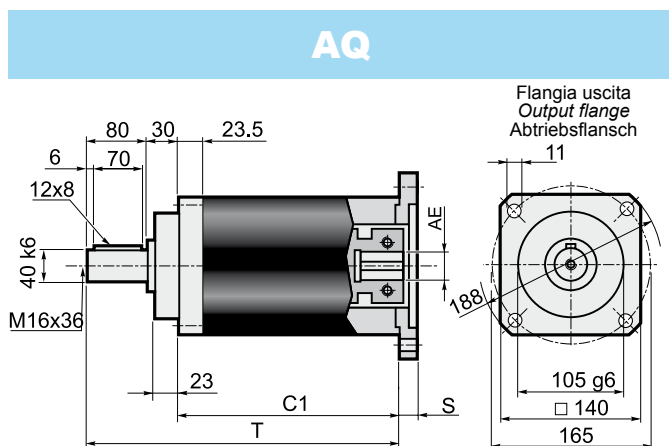

Stadi / Steps / Stufenzahl	1	2	AE= 15.87-16-19-22-24
C1	141	182.5	
T	251	292.5	
Stadi / Steps / Stufenzahl	1	2	AE= 28-32-35-38
C1	166	207.5	
T	276	317.5	

Dimensioni entrate / Input dimensions / Antriebsabmessungen

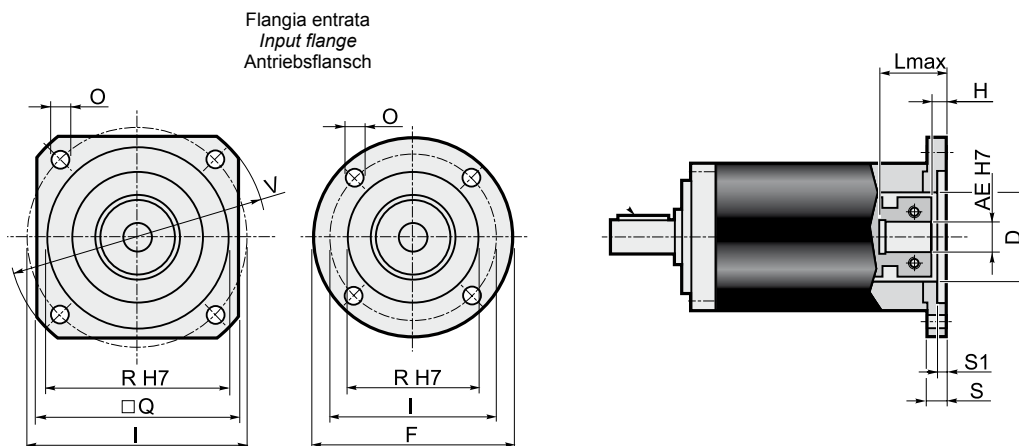

	Flange entrata / Input flange / Antriebsflansch									Albero entrata / Input shaft / Antriebswelle																	
										AE																	
										15.87		16		19		22		24		28		32		35		38	
F	Q	V	I	R (H7)	O	S	S1	D	L _{max}	H	L _{max}	H	L _{max}	H	L _{max}	H	L _{max}	H	L _{max}	H	L _{max}	H	L _{max}	H			
P01*	140	=	=	125.72	55.52	6.5	15	4	55.52	57.8	6.8	57.8	6.8	42.8	6.8	57.8	6.8	57.8	6.8	82.8	7.3	82.8	7.3	82.8	7.3	82.8	7.3
P02*	140	=	=	100	80	6.5	15	4	70	57.8	6.8	57.8	6.8	42.8	6.8	57.8	6.8	57.8	6.8	82.8	7.3	82.8	7.3	82.8	7.3	82.8	7.3
P03*	140	=	=	115	95	8.5	15	4.5	70	57.8	6.8	57.8	6.8	42.8	6.8	57.8	6.8	57.8	6.8	82.8	7.3	82.8	7.3	82.8	7.3	82.8	7.3
P04*	=	140	160	130	110	8.5	15	4.5	70	57.8	6.8	57.8	6.8	42.8	6.8	57.8	6.8	57.8	6.8	82.8	7.3	82.8	7.3	82.8	7.3	82.8	7.3
P05	=	142	190	165	130	11	15	4.5	70	57.8	6.8	57.8	6.8	42.8	6.8	57.8	6.8	57.8	6.8	82.8	7.3	82.8	7.3	82.8	7.3	82.8	7.3
P06	=	190	250	215	180	13	15	4.5	70	57.8	6.8	57.8	6.8	42.8	6.8	57.8	6.8	57.8	6.8	82.8	7.3	82.8	7.3	82.8	7.3	82.8	7.3
P07	=	250	300	265	230	13	15	4.5	70	57.8	6.8	57.8	6.8	42.8	6.8	57.8	6.8	57.8	6.8	82.8	7.3	82.8	7.3	82.8	7.3	82.8	7.3
P08	=	130	165	145	110	M 8	18	7	70	60.8	9.8	60.8	9.8	45.8	9.8	60.8	9.8	60.8	9.8	85.8	10.3	85.8	10.3	85.8	10.3	85.8	10.3
P09	=	180	230	200	114.3	13.5	22	11	70	64.8	13.8	64.8	13.8	49.8	13.8	64.8	13.8	64.8	13.8	89.8	14.3	89.8	14.3	89.8	14.3	89.8	14.3
P10	=	115	150	130	95	M 8	15	4.5	70	57.8	6.8	57.8	6.8	42.8	6.8	57.8	6.8	57.8	6.8	82.8	7.3	82.8	7.3	82.8	7.3	82.8	7.3
P11	=	180	230	198	155	13.5	22	7	120x11	64.8	13.8	64.8	13.8	49.8	13.8	64.8	13.8	64.8	13.8	89.8	14.3	89.8	14.3	89.8	14.3	89.8	14.3
P12	=	220	270	235	200	13.5	15	5	70	57.8	6.8	57.8	6.8	42.8	6.8	57.8	6.8	57.8	6.8	82.8	7.3	82.8	7.3	82.8	7.3	82.8	7.3
P13	=	190	250	215	130	13	15	4.5	70	57.8	6.8	57.8	6.8	42.8	6.8	57.8	6.8	57.8	6.8	82.8	7.3	82.8	7.3	82.8	7.3	82.8	7.3
P14	=	142	190	165	110	11	15	4.5	70	57.8	6.8	57.8	6.8	42.8	6.8	57.8	6.8	57.8	6.8	82.8	7.3	82.8	7.3	82.8	7.3	82.8	7.3
P15*	150	=	=	90	70	6.5	15	4	70	57.8	6.8	57.8	6.8	42.8	6.8	57.8	6.8	57.8	6.8	82.8	7.3	82.8	7.3	82.8	7.3	82.8	7.3
P16	=	146	200	177.8	114.3	10.5	15	3.5	70	57.8	6.8	57.8	6.8	42.8	6.8	57.8	6.8	57.8	6.8	82.8	7.3	82.8	7.3	82.8	7.3	82.8	7.3
P17	=	130	165	145	110	M 8	28	7	70	-	-	-	-	70.8	19.8	-	-	-	-	-	-	-	-	-	-	-	
P18	140	=	=	100	80	M 6	22	6	70	64.8	13.8	64.8	13.8	49.8	13.8	64.8	13.8	64.8	13.8	89.8	14.3	89.8	14.3	89.8	14.3	89.8	14.3

* Per assemblare il motore è necessario smontare la flangia dal riduttore (vedere schema di montaggio 2 a pag. 45).

* Before the mounting of the motor it is necessary to remove the flange from the gearbox (see structural arrangement 2 at the top of the page 45).

* Vor dem Einbauen des Motors soll die Getriebeflangsch abmontiert werden (siehe Bauanleitung 2 auf Seite 45).

1 Schema di montaggio / Assembly drawing / Bauanleitung 1

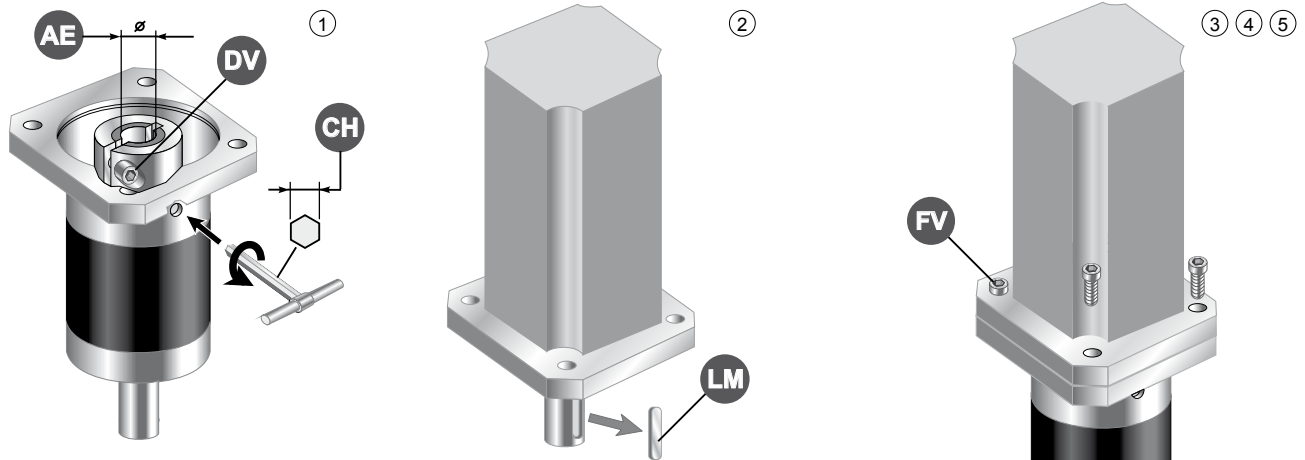

- 1 - Allentare la vite di serraggio del morsetto (DV)
- 2 - Estrarre la linguetta (LM) dall'albero motore
- 3 - Pulire le superfici di contatto delle flange motore e riduttore
- 4 - Calettare il motore sul riduttore evitando urti
- 5 - Stringere le viti di assemblaggio (FV) in modo alternato
- 6 - Assicurarsi che il morsetto venga serrato posizionandolo verso il motore e rispettando la fasatura dei tagli
- 7 - Serrare la vite (o le viti) del morsetto (DV) alla coppia (CS) indicata in tabella

- 1 - Unloose the fastening screw (or screws) of the clamp (DV)
- 2 - Remove the key (LM) from motor shaft
- 3 - Clean the contact surfaces of motor flange/gearbox flange
- 4 - Avoid impacts while fitting motor to gearbox
- 5 - Tighten the assembling screws (FV) alternately
- 6 - Fix the clamp towards the motor and tighten it in compliance with the cuts timing
- 7 - Tighten the clamp screw, or screws (DV) according to the torque (CS) reported in the table

- 1 - die Befestigungsschraube der Klammer (DV) lockern
- 2 - die Feder (LM) aus Motorwelle ziehen
- 3 - die Motorflansch / Getriebeflansch Kontaktfläche reinigen
- 4 - Motor und Getriebe ohne Stöße verkeilen
- 5 - die Befestigungsschrauben (FV) abwechselnd anziehen
- 6 - Die Klammer soll zum Motor angezogen. Dabei soll die Zuendeinstellung der Schnitte geachtet
- 7 - die Schraube (oder Schrauben) der Klammer (DV) zu dem in der Tabelle angegebenen Anzugsmoment anziehen

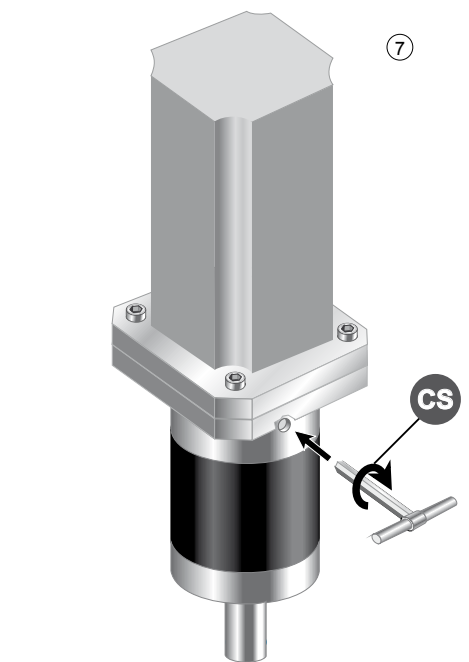
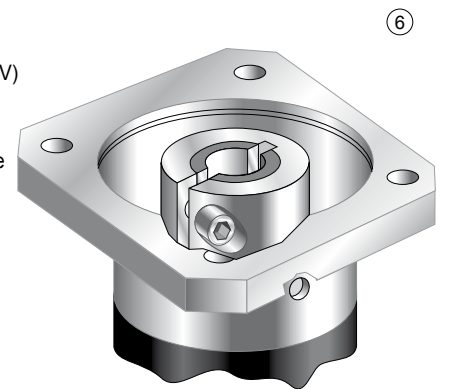

EP 55	AE	6	6.35	7	8	9	9.52	11				
	DV	M4 x 16										
	NV	1										
	CH	3										
	CS [Nm]	4.8										
EP 75	AE	6	6.35	7	8	9	9.52	11	12	12.7	14	
	DV	M4 x 16										
	NV	1										
	CH	3										
	CS [Nm]	4.8										
EP 90	AE	9	9.52	11	12	12.7	14	15.87	16	19		
	DV	M4 x 16						M5 x 20				
	NV	1						1				
	CH	3						4				
	CS [Nm]	4.8						9.4				
EP 120	AE	12.7	14	15.87	16	19	22	24	25	28		
	DV	M4 x 16		M5 x 20			M6 x 20					
	NV	1		1			2					
	CH	3		4			5					
	CS [Nm]	4.8		9.4			16.2					
EP 155	AE	15.87	16	19	22	24	28	32	35	38		
	DV	M6 x 20			M6 x 20			M6 x 20				
	NV	1			2			3				
	CH	5			5			5				
	CS [Nm]	16.2			16.2			16.2				

Tutte le viti hanno classe di resistenza 12.9
 All screws supplied according to strenght class 12.9
 Alle Schrauben nach Festigkeitsklasse 12.9 geliefert

AE= Albero entrata / Input shaft / Antriebswelle
 DV= Diametro vite / Screw diameter / Schraubendurchmesser

NV= Numero viti / Number of screw / Schraubenanzahl
 CS= Coppia di serraggio / Setting torque / Spannungsmoment

2

Schema di montaggio / Assembly drawing / Bauanleitung 2

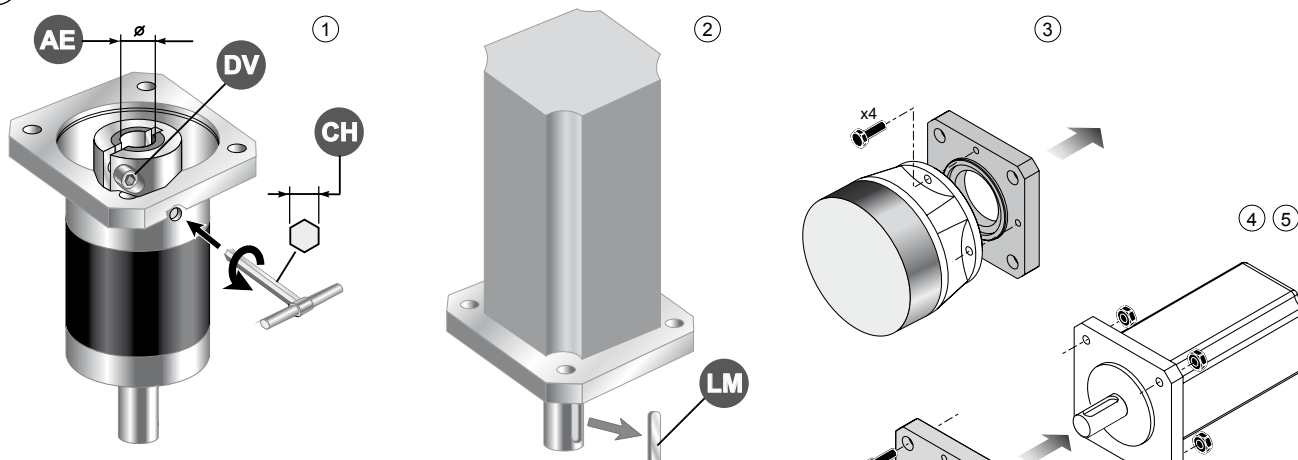

- 1 - Allentare la vite di serraggio del morsetto (DV)
- 2 - Estrarre la linguetta (LM) dall'albero motore
- 3 - Smontare la flangia dal riduttore
- 4 - Pulire le superfici di contatto delle flange motore e riduttore
- 5 - Fissare la flangia sul motore
- 6 - Calettare il motore sul riduttore evitando urti
- 7 - Stringere le viti di assemblaggio (FV) in modo alternato
- 8 - Assicurarsi che il morsetto venga serrato posizionandolo verso il motore e rispettando la fasatura dei tagli
- 9 - Serrare la vite (o le viti) del morsetto (DV) alla coppia (CS) indicata in tabella

- 1 - Unloose the fastening screw (or screws) of the clamp (DV)
- 2 - Remove the key (LM) from motor shaft
- 3 - Remove the flange from the gearbox
- 4 - Clean the contact surfaces of motor flange/gearbox flange
- 5 - Fix the flange on the motor
- 6 - Avoid impacts while fitting motor to gearbox
- 7 - Tighten the assembling screws (FV) alternatively
- 8 - Fix the clamp towards the motor and tighten it in compliance with the cuts timing
- 9 - Tighten the clamp screw, or screws (DV) according to the torque (CS) reported in the table

- 1 - die Befestigungsschraube der Klammer (DV) lockern
- 2 - die Feder (LM) aus Motorwelle ziehen
- 3 - die Flansch von Getriebe abmontieren
- 4 - die Motorflansch / Getriebe-flansch Kontaktfläche reinigen
- 5 - die Flansch an Motor befestigen
- 6 - Motor und Getriebe ohne Stöße verkeilen
- 7 - die Befestigungsschrauben (FV) abwechselnd anziehen
- 8 - Die Klammer soll zum Motor angezogen. Dabei soll die Zuendeinstellung de Schnitte geachtet
- 9 - die Schraube (oder Schrauben) der Klammer (DV) zu dem in der Tabelle angegebenen Anzugsmoment anziehen

EP 55	AE	6	6.35	7	8	9	9.52	11					
	DV	M4 x 16											
	NV	1											
	CH	3											
	CS [Nm]	4.8											
EP 75	AE	6	6.35	7	8	9	9.52	11	12	12.7	14		
	DV	M4 x 16											
	NV	1											
	CH	3											
	CS [Nm]	4.8											
EP 90	AE	9	9.52	11	12	12.7	14	15.87	16	19			
	DV	M4 x 16									M5 x 20		
	NV	1									1		
	CH	3									4		
	CS [Nm]	4.8									9.4		
EP 120	AE	12.7	14	15.87	16	19	22	24	25	28			
	DV	M4 x 16			M5 x 20				M6 x 20				
	NV	1			1				2				
	CH	3			4				5				
	CS [Nm]	4.8			9.4				16.2				
EP 155	AE	15.87	16	19	22	24	28	32	35	38			
	DV	M6 x 20			M6 x 20				M6 x 20				
	NV	1			2				3				
	CH	5			5				5				
	CS [Nm]	16.2			16.2				16.2				

Tutte le viti hanno classe di resistenza 12.9

All screws supplied according to strenght class 12.9

Alle Schrauben nach Festigkeitsklasse 12.9 geliefert

AE= Albero entrata / Input shaft / Antriebswelle

DV= Diametro vite / Screw diameter / Schraubendurchmesser

NV= Numero viti / Number of screw / Schraubenanzahl

CS= Coppia di serraggio / Setting torque / Spannungsmoment

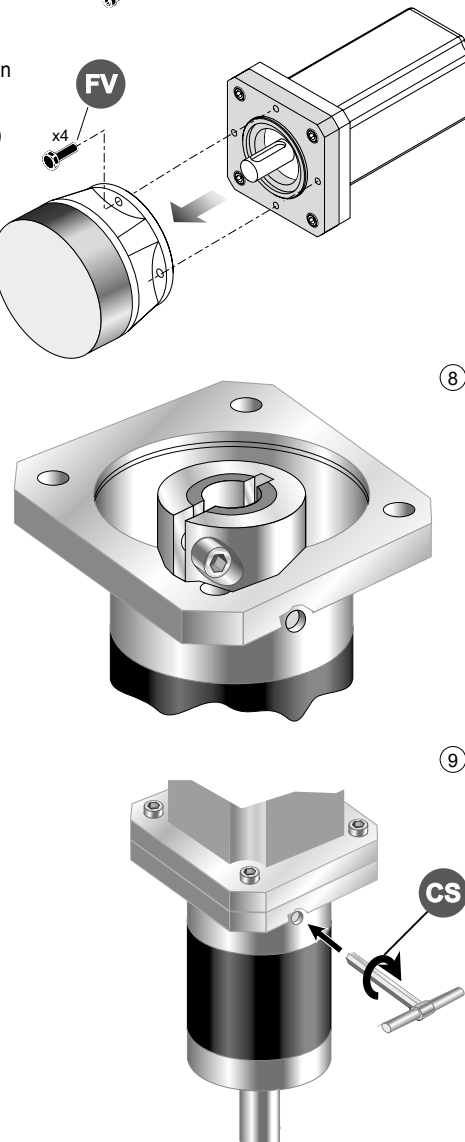

3.1 Esempi di applicazioni

3.1 Examples of applications

3.1 Anwendungsbeispiele

Carrello scorrevole

Sliding carriage

Laufwagen

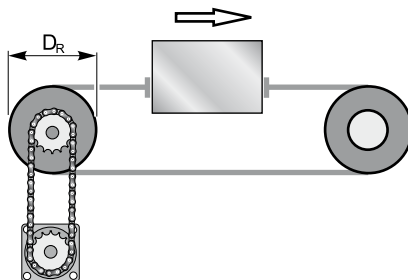

L'applicazione prevede la movimentazione lineare di una tavola tramite una catena (rapporto di riduzione della trasmissione: $i=1$)
 La massa del carrello è di $m=200$ kg e $D_R=0.1$ m.
 Il carrello deve essere accelerato in $t_a=0.2$ s ad una velocità massima $v_2=0.6$ m/s.
 Il rapporto di riduzione del riduttore è $i=20$.
 La forza resistente che si oppone allo spostamento è pari a $F=500$ N (data dal prodotto della forza per il coefficiente di attrito).

The application requires the linear motion of a table by means of a chain (reduction ratio of the transmission: $i=1$).
 The carriage mass is $m=200$ Kg and $D_R=0.1$ m.
 The carriage has to be accelerated in $t_a=0.2$ s to a maximum speed $v_2=0.6$ m/s.
 The reduction ratio of the gearbox is $i=20$.
 The resisting force acting against the motion is $F=500$ N (product of the force by the coefficient of friction).

Die Applikation sieht die Linearbewegung einer Scheibe durch eine Kette vor. (Übersetzungsverhältnis: $i=1$)
 Die Masse der Wagen ist $m=200$ Kg und $D_R=0.1$ m. Der Wagen soll in $t_a=0.2$ s bis Höchstgeschwindigkeit $v_2=0.6$ m/s beschleunigt werden.
 Das Übersetzungsverhältnis des Getriebes ist $i=20$.
 Die Widerstandskraft, die gegen die Bewegung wirkt, ist $F=500$ N (Produkt von Kraft mal Reibungskoeffizient)

- Determinazione della coppia resistente T_{RES}

$$T_{RES} = F \cdot D_R / 2 = 500 \cdot 0.1 / 2 = 25 \text{ Nm}$$

- Calculation of resisting torque T_{RES}

$$T_{RES} = F \cdot D_R / 2 = 500 \cdot 0.1 / 2 = 25 \text{ Nm}$$

- Berechnung von Widerstandsdrehmoment

$$T_{RES} = F \cdot D_R / 2 = 500 \cdot 0.1 / 2 = 25 \text{ Nm}$$

- Determinazione della coppia resistente T_{IN} dovuta all'inerzia

$$T_{IN} = F_i \cdot D_R / 2 \text{ (Nm)}$$

- Calculation of resisting torque of inertia T_{IN}

$$T_{IN} = F_i \cdot D_R / 2 \text{ (Nm)}$$

- Berechnung von Trägheitsdrehmoment T_{IN}

$$T_{IN} = F_i \cdot D_R / 2 \text{ (Nm)}$$

Dove F_i è la forza di inerzia, la quale, nel caso di traslazione, vale:

$$F_i = m \cdot a \quad \text{(N)}$$

F_i is the inertial force which, in case of translation, is:

$$F_i = m \cdot a \quad \text{(N)}$$

F_i ist die Trägheit, die im Falle von Translation wie folgt ist :

$$F_i = m \cdot a \quad \text{(N)}$$

In questo caso, l'accelerazione risulta:

$$a = (v_2 - v_0) / t_a \quad \text{(m/s}^2\text{)}$$

con v_2 = velocità finale (m/s)
 v_0 = velocità iniziale (m/s)
 t_a = tempo di accelerazione (s)

quindi:

$$a = (0.6 - 0) / 0.2 = 3 \text{ m/s}^2$$

$$F_i = 200 \cdot 3 = 600 \text{ N}$$

$$T_{IN} = 600 \cdot 0.1 / 2 = 30 \text{ Nm}$$

In this case, acceleration is:

$$a = (v_2 - v_0) / t_a \quad \text{(m/s}^2\text{)}$$

v_2 = final speed
 v_0 = initial speed
 t_a = acceleration time (s)

Therefore:

$$a = (0.6 - 0) / 0.2 = 3 \text{ m/s}^2$$

$$F_i = 200 \cdot 3 = 600 \text{ N}$$

$$T_{IN} = 600 \cdot 0.1 / 2 = 30 \text{ Nm}$$

In diesem Fall ist die Beschleunigung wie folgt:

$$a = (v_2 - v_0) / t_a \quad \text{(m/s}^2\text{)}$$

Mit v_2 = Endgeschwindigkeit
 v_0 = Startgeschwindigkeit
 t_a = Beschleunigungszeit(s)

Folglich:

$$a = (0.6 - 0) / 0.2 = 3 \text{ m/s}^2$$

$$F_i = 200 \cdot 3 = 600 \text{ N}$$

$$T_{IN} = 600 \cdot 0.1 / 2 = 30 \text{ Nm}$$

Pertanto, la coppia da prendere in considerazione, per dimensionare correttamente l'applicazione, vale:

$$T_2 = T_{RES} + T_{IN} = 25 + 30 = 55 \text{ Nm}$$

As a result, for the purpose of a correct dimensioning of the application, the following torque has to be taken into consideration:

$$T_2 = T_{RES} + T_{IN} = 25 + 30 = 55 \text{ Nm}$$

Damit die Dimensionierung der Applikation korrekt ist, ist das folgendes Drehmoment zu betrachten:

$$T_2 = T_{RES} + T_{IN} = 25 + 30 = 55 \text{ Nm}$$

In funzione di questo risultato si dovrà individuare un adeguato motore (in prima approssimazione: $T_{MOT} = (T_2 / i) \cdot R_d$), tale cioè da garantire una coppia motrice sufficiente a vincere gli attriti e le inerzie presenti. Successivamente, in funzione delle caratteristiche del motore scelto e delle rimanenti specifiche dell'applicazione (ciclo di lavoro, numero di cicli all'ora ecc.) si procede selezionando opportunamente il riduttore (v. selezione del riduttore).

This value has to be taken into account when selecting the motor (approx. $T_{MOT} = (T_2 / i) \cdot R_d$). The motor torque should be high enough as to overcome friction and inertia forces. Subsequently, it is possible to proceed with the selection of the gearbox on the basis of motor specifications and features of application (operation cycle, no. cycles per hour, etc.) (see selection of the gearbox).

Von diesen Wert hängt die Wahl des Motors (annähernd : $T_{MOT} = (t_2 / i) \cdot R_d$) ab. Das Antriebsdrehmoment muss ausreichend hoch sein, um Reibungs- und Trägheitskräfte überwinden zu können. Schließlich wird das Getriebe abhängig von Applikation (Arbeitszyklus, Zyklen pro Stunde, u.s.w.) und Motoreigenschaften gewählt. (Siehe Wahl des Getriebes).

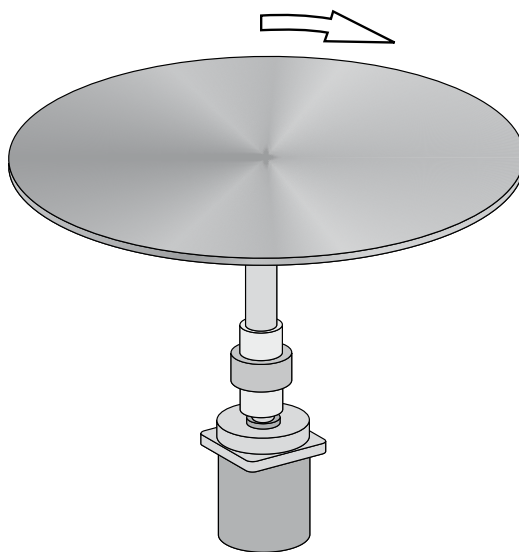
Tavola rotante
Revolving table
Drehscheibe

L'applicazione prevede la messa in rotazione di una tavola cilindrica di massa pari a $m=20\text{kg}$ e raggio $r=0.5\text{m}$.

Tale tavola deve essere accelerata da $n_0 = 0 \text{ min}^{-1}$ a $n_1 = 300 \text{ rpm}$ in $t_a = 0.3 \text{ s}$.

Il rapporto di riduzione del riduttore è $i=20$.

Si suppone che la coppia resistente per mantenere in rotazione uniforme la tavola sia trascurabile rispetto alla coppia legata all'inerzia dell'applicazione.

The application requires the rotation of a cylindrical table with mass $m=20 \text{ Kg}$ and radius $r=0.5\text{m}$.

The table has to be accelerated from $n_0=0 \text{ rpm}$ to $n_1=300 \text{ min}^{-1}$ in $t_a=0.3\text{s}$.

The reduction ratio of the gearbox is $i=20$.

The resisting torque, which enables uniform rotation of the table, is assumed to be negligible compared to the torque caused by the inertia of the application.

Die Applikation sieht die Drehung einer zylindrischen Scheibe vor, deren Masse $m=20\text{Kg}$ ist und deren Halbmesser $r=0.3$ ist.

Solche Scheibe soll von $n_0 = 0 \text{ U/Min}$ bis $n_1=300 \text{ min}^{-1}$ in $t_a=0.3\text{s}$ beschleunigt werden. Das Übersetzungsverhältnis des Getriebes ist $i=20$.

Es wird angenommen, dass das zur gleichmäßigen Drehung der Scheibe dienenden Widerstandsrehmoment unbeträchtlich im Vergleich zum Trägheitsmoment ist.

Quindi, in questo caso:

$$T_2 = T_{IN} = J \cdot a_a \quad (\text{Nm})$$

Dove $J \text{ (kgm}^2\text{)}$ è il momento d'inerzia di massa della tavola rotante, ed $a_a \text{ (rad/s}^2\text{)}$ è la accelerazione angolare.

$$J = (m \cdot r^2) / 2 = (20 \cdot 0.5^2) / 2 = 2.5 \text{ kgm}^2$$

$$a_a = \frac{\omega_1 - \omega_0}{t_a} \quad (\text{rad/s}^2)$$

$$\omega_1 = (2 \cdot \pi \cdot n_1) / 60 = (2 \cdot \pi \cdot 300) / 60 = 31.4 \text{ rad/s}$$

Quindi:

$$a_a = \frac{31.4 - 0}{0.3} = 104.6 \quad (\text{rad/s}^2)$$

Infine:

$$T_2 = T_{IN} = 2.5 \cdot 104.6 = 261 \text{ Nm}$$

In funzione di questo risultato si dovrà individuare un adeguato motore (in prima approssimazione: $T_{MOT} = (T_2 / i) \cdot R_d$), tale cioè da garantire una coppia motrice sufficiente a vincere gli attriti e le inerzie presenti. Successivamente, in funzione delle caratteristiche del motore scelto e delle rimanenti specifiche dell'applicazione (ciclo di lavoro, numero di cicli all'ora ecc.) si procede selezionando opportunamente il riduttore (v. selezione del riduttore).

Therefore, in this case:

$$T_2 = T_{IN} = J \cdot a_a \quad (\text{Nm})$$

$J \text{ (kgm}^2\text{)}$ is the moment of inertia of the mass of the revolving table and $a_a \text{ (rad/s}^2\text{)}$ is the angular acceleration.

$$J = (m \cdot r^2) / 2 = (20 \cdot 0.5^2) / 2 = 2.5 \text{ kgm}^2$$

$$a_a = \frac{\omega_1 - \omega_0}{t_a} \quad (\text{rad/s}^2)$$

$$\omega_1 = (2 \cdot \pi \cdot n_1) / 60 = (2 \cdot \pi \cdot 300) / 60 = 31.4 \text{ rad/s}$$

Therefore:

$$a_a = \frac{31.4 - 0}{0.3} = 104.6 \quad (\text{rad/s}^2)$$

In conclusion:

$$T_2 = T_{IN} = 2.5 \cdot 104.6 = 261 \text{ Nm}$$

This value has to be taken into account when selecting the motor (approx. $T_{MOT} = (T_2 / i) \cdot R_d$). The driving torque should be high enough as to overcome friction and inertia forces. Subsequently, proceed with the selection of the gearbox on the basis of motor specifications and features of application (operation cycle, no. cycles per hours, etc.) (see selection of the gearbox).

Folglich, in diesem Fall:

$$T_2 = T_{IN} = J \cdot a_a \quad (\text{Nm})$$

$J \text{ (kgm}^2\text{)}$ ist das Trägheitsmoment der Masse der Drehscheibe und $a_a \text{ (rad/s}^2\text{)}$ ist die Winkelbeschleunigung.

$$J = (m \cdot r^2) / 2 = (20 \cdot 0.5^2) / 2 = 2.5 \text{ kgm}^2$$

$$a_a = \frac{\omega_1 - \omega_0}{t_a} \quad (\text{rad/s}^2)$$

$$\omega_1 = (2 \cdot \pi \cdot n_1) / 60 = (2 \cdot \pi \cdot 300) / 60 = 31.4 \text{ rad/s}$$

Folglich:

$$a_a = \frac{31.4 - 0}{0.3} = 104.6 \quad (\text{rad/s}^2)$$

Schließlich:

$$T_2 = T_{IN} = 2.5 \cdot 104.6 = 261 \text{ Nm}$$

Von diesen Wert hängt die Wahl des Motors (annähernd: $T_{MOT} = (T_2 / i) \cdot R_d$) ab. Das Antriebsdrehmoment muss ausreichend hoch sein, um Reibungs- und Trägheitskräfte überwinden zu können. Schließlich wird das Getriebe abhängig von Applikation (Arbeitszyklus, Zyklen pro Stunde, u.s.w.) und Motoreigenschaften gewählt (siehe Wahl des Getriebes).

Calcolo dell'inerzia J / Calculation of inertia J / Berechnung der Trägheit J

 $J = MR^2$	 $J = \frac{1}{2}MR^2$	 $J = \frac{M(R^2 + r^2)}{2}$	 $J = \frac{M(a^2 + b^2)}{12}$
 $J = \frac{2}{5}MR^2$	 $J = \frac{M}{4} \left(\frac{h^2}{3} + R^2 \right)$	 $J = \frac{M}{4} \left(\frac{h^2}{3} + R^2 + r^2 \right)$	 $J = \frac{M(h^2 + a^2)}{12}$

M	[Kg]	Massa	Weight	Maße
a, b, h	[m]	Dimensioni	Dimensions	Abmessungen
J	[Kgm ²]	Inerzia	Inertia	Trägheitsmoment

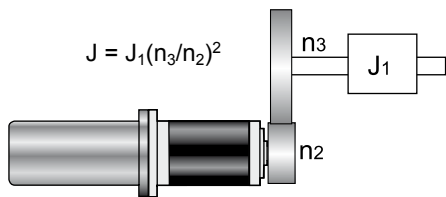

J = inerzia riferita all'albero uscita del riduttore con velocità n_2 [rad/s] derivante da una massa con inerzia J_1 e ruotante a velocità n_3 [rad/s].

J = inertia referred to the gearbox output shaft with speed n_2 [rad/s] resulting from a mass with inertia J_1 rotating at n_3 speed [rad/s].

J = Trägheit mit Bezug auf Getriebeabtriebswelle mit Drehzahl n_2 [rad/s], die von einer Masse mit Trägheit J_1 zu n_3 Drehzahl ableitet [rad/s].

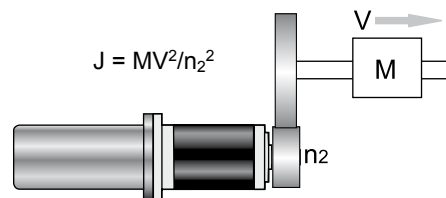

J = inerzia riferita all'albero uscita del riduttore con velocità n_2 [rad/s] derivante da una massa traslante M [Kg] a velocità V [m/s].

J = inertia referred to the gearbox output shaft with speed n_2 [rad/s] resulting from a translating mass M [Kg] at V speed [m/s].

J = Trägheit mit Bezug auf Getriebeabtriebswelle mit Drehzahl n_2 [rad/s], die von einer Translation-Masse M [Kg] zu V Drehzahl [m/s] ableitet.

Relazioni fondamentali fra coppia T [Nm], inerzia J [Kgm²] e accelerazione angolare a_a [rad/s²].

Fundamental relations between torque T [Nm], inertia J [Kgm²] and angular acceleration a_a [rad/s²].

Wesentliche Relationen zwischen Drehmoment T [Nm], Trägheit J [Kgm²] und Winkelbeschleunigung a_a [rad/s²].

$$T = J \cdot a_a$$

Relazioni fondamentali fra coppia e potenza in entrata (T1, P1) e in uscita (T2, P2), il rendimento Rd e il rapporto di riduzione i del riduttore.

Fundamental relations between input torque and power (T1, P1), output torque and power (T2, P2), efficiency Rd, gearbox reduction ratio i.

Wesentliche Relationen zwischen Antriebsdrehmoment und -leistung (T1, P1), Abtriebsdrehmoment und -leistung (T2, P2), Wirkungsgrad Rd, Untersetzungsverhältnis i des Getriebes.

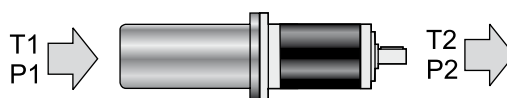

$$P2 = P1 \cdot Rd \quad T2 = T1 \cdot i \cdot Rd$$

**CONDIZIONI GENERALI DI GARANZIA**

La garanzia relativa a difetti di costruzione ha la durata di un anno dalla data di fatturazione delle merci. Tale garanzia comporta per la TRAMEC l'onere della sostituzione o riparazione delle parti difettose ma non ammette ulteriore addebito per eventuali danni diretti o indiretti di qualsiasi natura. La garanzia decade nel caso in cui non siano state osservate le disposizioni riportate nel manuale di uso e manutenzione e/o siano state eseguite riparazioni o apportate modifiche senza nostro consenso scritto.

La merce di ritorno sarà da noi accettata solo se spedita franco di ogni spesa.

GENERAL CODITIONAL OF WARRANTY

Warranty for manufacturing defects will expire one-year the invoicing date. TRAMEC will replace or repair defective parts but will not accept any further charges for direct or indirect damages of any kind. The warranty will become null and void if the instructions given in the use and maintenance manual are not complied with or if repairs or changes are carried out without our prior written authorization.

Returned goods will be accepted only if delivered free of any charge.

ALLGEMEINE GARANTIEBEDINGUNGEN

Die Garantie auf Herstellungsfehler dauert ein Jahr ab Rechnungsdatum der Ware. Aufgrund Garantie unterliegt der TRAMEC die Pflicht der Ersetzung oder Reparatur der defekten Teile, jedoch nicht die Übernahme weiterer Belastungen für direkte oder indirekte Schäden egal welcher Natur. Die Garantie verfällt bei Nichtbeachtung der in der betreffenden „Betriebs- und Instandhaltungsanleitung“ angeführten Anweisungen und/oder falls ohne unsere vorausgehende schriftliche Genehmigung Reparaturen oder Änderungen vorgenommen wurden.

Die an uns zurückgesendete Ware akzeptieren wir nur wenn gebührenfrei geliefert.

REVISIONI**REVISIONS****ÄNDERUNG**

06/2011	Modificata altezza EP75	06/2011	Change of EP 75 height	06/2011	Änderung der Höhe des Getriebes EP 75
01/2012	Ridotto gioco angolare EP	01/2012	Decreased angular backlash EP	01/2012	Reduziert Winkelspiel EP
03/2014	Modificate: dimensioni PAM REP 75 dimensioni C1 EP120	03/2014	Modify: dimensions PAM REP 75 dimensions C1 - EP120	03/2014	geändert: Größe PAM REP 75 Größe C1 - EP 120
04/2015	Aggiunti PAM REP Aggiunti PAM EP	04/2015	Add PAM REP Add date PAM EP	04/2015	Neue PAM REP Neue PAM EP

04/2015

Questo catalogo annulla e sostituisce ogni precedente edizione o revisione. Tutti i dati elencati sono indicativi e s'intendono senza impegno alcuno da parte nostra. Ci riserviamo il diritto di apportare modifiche senza preavviso.

This catalogue cancels and replaces any previous edition and revision. All listed data are approximate and it's understood that this entails no obligation on our part. We reserve the right to implement modifications without notice.

Mit der Ausgabe dieses Katalogs annullieren sich gleichzeitig alle bisherigen Katalogen. Sämtliche Daten sind Berechnete Werte die für den Verkäufer unverbindlich sind. Der Verkäufer behält sich das Recht vor, Änderungen, ohne eine vorhergehende Advisierung durchzuführen.