



QUALIMETAL[®]
BÂTIMENTS MÉTALLIQUES



QUALIMETAL[®]



CUALIMETAL[®]
BÂTIMENTS MÉTALLIQUES



GH

5t

Index

1. Entreprise
2. Philosophie et Méthodologie
3. Ingénierie
4. Qualité et Marquage CE
5. Gestion & Renting
6. Solutions Modulaires
(Propres Produits)
 - ECORAPID®
 - MECARAPID®
 - PLENAVE®
 - NAVERAPID®
 - NAVEXPRESS®
 - MARQUISOL®
7. Halls sur mesure
8. Secteurs
 - Industriel
 - Logistique
 - Recyclage
 - Automobile
 - Agricole
 - Aéronautique
 - Bureaux
 - Centres de Sports
 - Construcctions Temporaires



*Votre hall industriel simplement et avec
efficacité partout dans le monde.*



Entreprise

CUALIMETAL,S.A.U. est dédiée à la construction de halls métalliques sur mesure et totalement personnalisés.

Comptant plus de 25 ans d'expérience dans le secteur de l'acier et disposant de références dans le monde entier en structures métalliques pour bâtiments industriels, halls logistiques, pavillons, hangars, etc., nous offrons toujours la meilleure solution.



SIEGE

Parque Empresarial Puerta Norte, Calle J.
Ctra. N-330, Salida 509. 50820 Zaragoza (ESPAGNE)
Tel. (+34) 976 348 282 Fax (+34) 976 314 302

www.cualimetal.com





Quand une entreprise réunit connaissance, travail, engagement, créativité et établit sa propre méthode, elle devient une organisation capable de relever tous les challenges.



Philosophie et Méthodologie

Notre objectif, parvenir à satisfaire à 100% nos clients grâce à l'expérience attestée de nos solutions.

Expansion Internationale, des projets remarquables dans le monde.

Afrique: Guinée Equatoriale, Mauritanie, Angola, Mozambique, Congo, République démocratique du Congo, Burkina Faso, Maroc, Algérie.

Amérique: Mexique, Nicaragua, Costa Rica, Salvador, Uruguay, Paraguay, Venezuela, Colombie, Cuba, Etats-Unis.

Europe: Espagne, France, Portugal, Italie, Roumanie, Ukraine, Pologne, Bulgarie, Malte.

Asie: Indonésie, Kazakhstan.

Notre raison d'être, notre propre technologie et brevets. Conception, fabrication et équipements de montage.

La Qualité dans tous les processus

- Garantie de validité technique grâce à notre propre ingénierie et au respect des exigences établies dans les réglementations locales de chaque lieu.
- Des systèmes de construction innovants et efficaces (département de R+D+i).
- Qualité des montages avec les équipements de l'entreprise ainsi que des matériaux employés.
- Qualité du service intégral attestée par le **“certificat de qualité ISO 9001:2015”** de nos procédures.

Rapidité de tous les processus

- Rapidité des démarches techniques (calculs, plans, etc.).
- Rapidité de fabrication.
- Rapidité d'exécution.
- Respect rigoureux des délais fixés au préalable.

Polyvalence et flexibilité

Technique: Le matériau utilisé, l'acier permet une plus grande flexibilité et l'adaptation aux besoins du client, présents et surtout futurs: agrandissements, délocalisation, etc.

Montage: Nos équipes possèdent une longue expérience et grande formation qui se traduisent par une vaste connaissance des produits et des matériaux que nous employons et permet de résoudre toute modification du client “sur place”.



Nous recherchons l'efficacité maximale dans chacune des phases de nos projets avec des méthodes développées et brevetées visant la rapidité et la simplicité.



Ingénierie

Notre département d'ingénierie collabore directement avec le client et réalise le calcul et la conception de ses produits à l'aide des logiciels de calcul et de conception 3D les plus avancés.

Cette capacité technologique qui se joint à l'expérience de son équipe humaine, composée d'ingénieurs hautement qualifiés, permet une exécution conforme aux besoins du client.

Innovation et avant-garde

Enjeu d'amélioration continue des produits existants dans l'entreprise.

Développement de nouvelles conceptions de produits, de processus ou de services nouveaux, élaboration de prototypes ou projets pilote.

Innovation technologique, pour améliorer les processus de production et de fabrication.

Mécanismes de protection des nouveaux produits: brevets, modèles d'utilité.

Gestion des produits et des marques propres de l'entreprise.



Nos systèmes brevetés permettent de réaliser le montage de la manière la plus rapide et pratique, gagnent en temps et en coût et garantissent, à la fois, la qualité de la construction.



Qualité et Marquage CE

Nos systèmes brevetés permettent de réaliser le montage de la manière la plus rapide et pratique possible, permettant de gagner à la fois en temps, en coût et en qualité de construction.

Qualité, fiabilité et sécurité maximales, dans le respect de toutes les exigences établies par la législation et la réglementation en vigueur **“certifié de qualité ISO 9001:2015”**.

Souplesse suffisante pour s'adapter au mieux non seulement à la détection des défauts mais aussi à leur prévention.

Amélioration de tous les processus à mettre en œuvre à destination principale de la satisfaction des clients et du personnel.

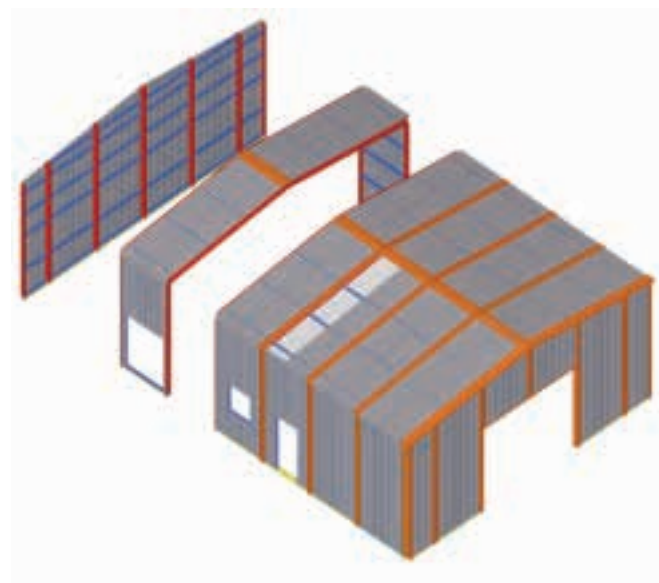

CE
0370-CPR-1663





Notre réactivité et nos méthodes solides et bien définies offrent des solutions efficaces et économiques dans les meilleurs délais, et ce partout dans le monde.



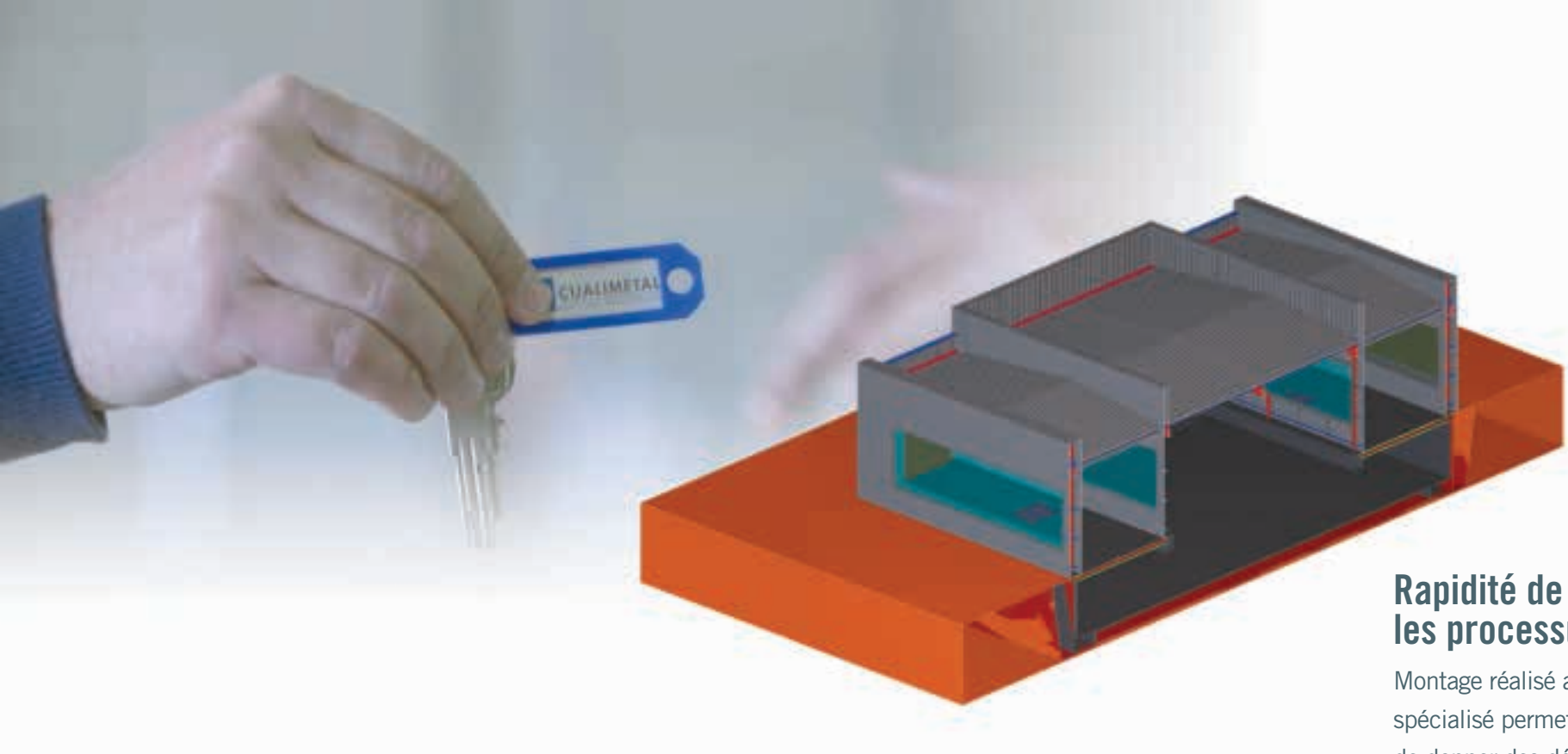

Rapidité de tous les processus

Montage réalisé avec son propre personnel spécialisé permettant à **CUALIMETAL, S.A.U.** de donner des délais de livraison même immédiats, par conséquent, incomparables à d'autres produits.

Location des installations

Nos systèmes rapides de fabrication et de montage nous permettent d'offrir un plan de renting pour tous les projets où d'installation d'un hall industriel est temporaire. Nous nous chargeons tant de l'installation que d'un éventuel démontage, et nous livrons clé en main.

Gestion & Renting

Versatilité et flexibilité

Elles se traduisent par la capacité de démontage, la simplicité de l'agrandissement et la variation des bardages, avec une récupération de 100% des matériaux pour les besoins de relocalisation et/ou de revente.



Technologie et brevets propres avec plus de 2000 références et des méthodes propres qui nous positionnent comme entreprise leader.

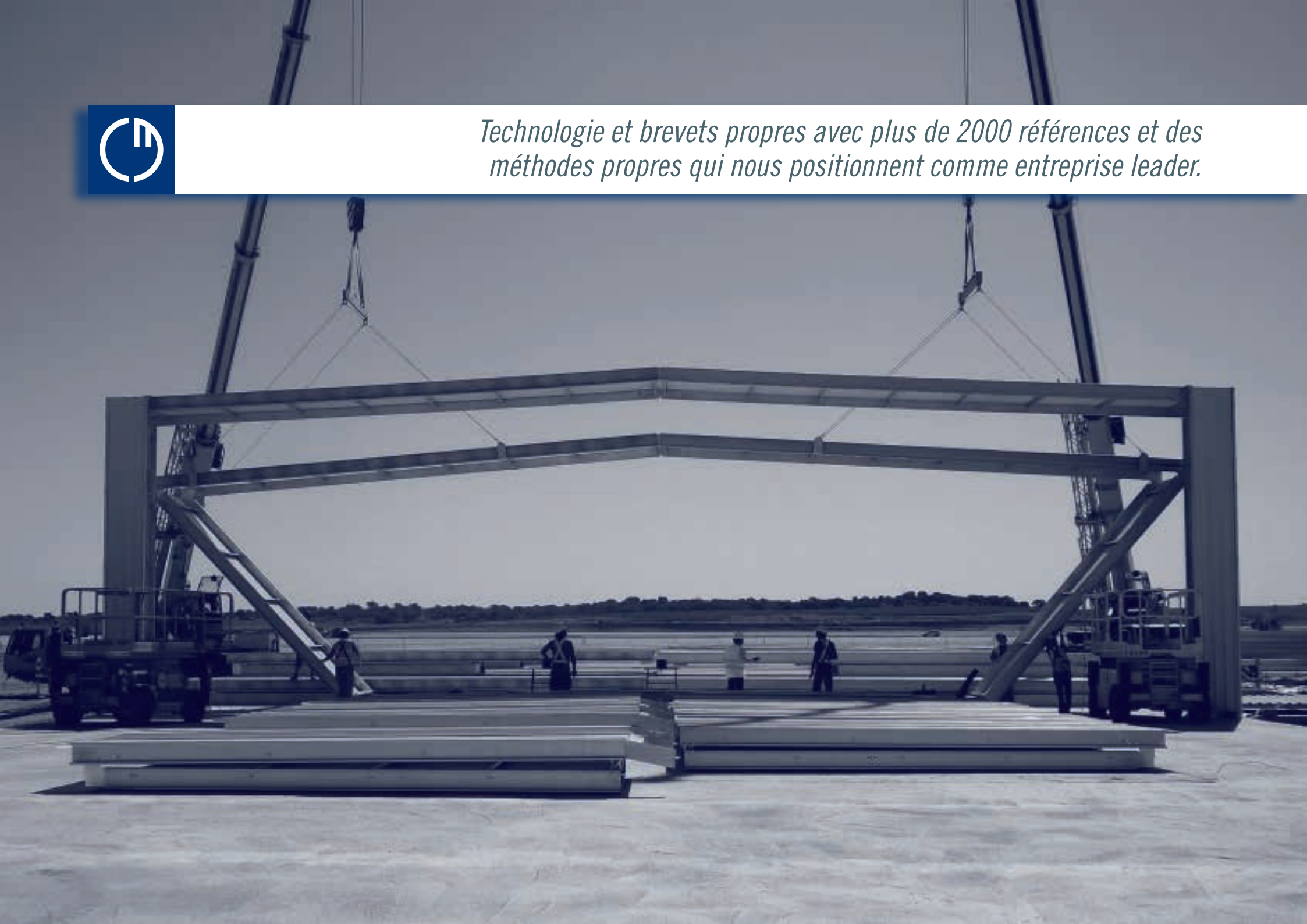

Solutions Modulaires Nos propres Produits

Conception, fabrication et montage propres, de hall métallique **“clé en main”** au principe de halls de stockage préfabriqués ou industrielles modulaires.

Notre personnel hautement qualifié, composé d'économistes, d'ingénieurs, de maîtres d'œuvre projeteurs, de diplômés en prévention des risques professionnels et d'équipes de montage.

Solutions métalliques démontables

Rapidité, économie, qualité et polyvalence. Avec ces constructions de structure métallique légère, en acier, nous répondons à tous les besoins de halls économiques, rapides et polyvalents en structure métallique démontable.

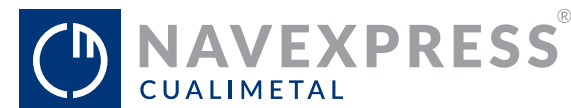



ECORAPID[®]

CUALIMETAL

Simple, rapides et économiques

C'est le hall modulaire préfabriqué de construction rapide et économique qui s'adapte le mieux à vos besoins en termes de temps, de prix et de conception.

En moins de 4 semaines après la signature du contrat, vous pourrez disposer de votre hall industriel, hangar, hall de stockage, pavillon, hall agricole, garage, atelier, installé/e...

Economie, rapidité et versatilité le définissent. Sa structure métallique et ses bardages sont conçus pour satisfaire les besoins actuels de construction industrielle, agricole, particuliers, etc., de tout client.

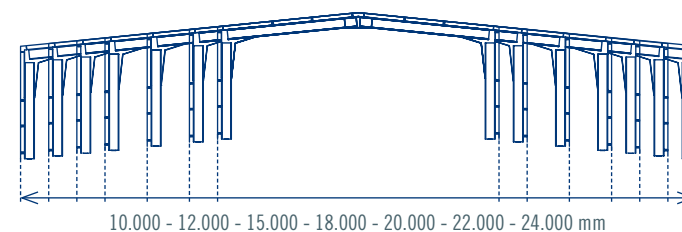
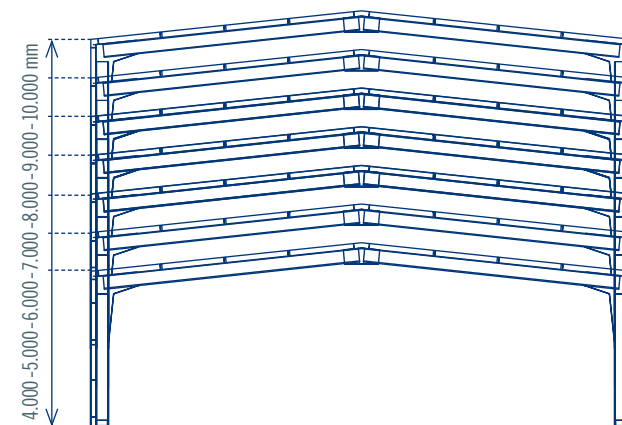

Gamme de couleurs disponible

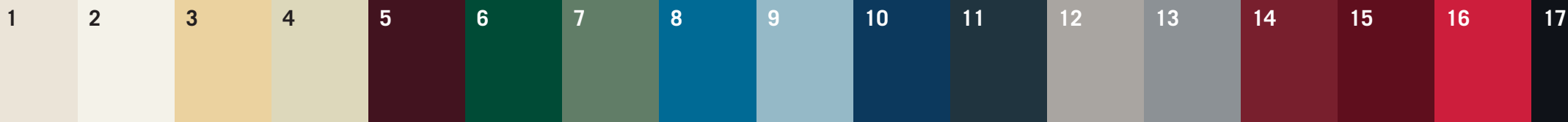

ENTREPÔTS ET
AGRANDISSEMENT
HALLES AGRICOLES
BESOINS IMMEDIATS
LOGISTIQUES - GARAGES
VEHICULES
ÉVENEMENTS
CENTRES DE SPORTS
BOXES, CENTRES EQUESTRES
HANGARS

CENTRES DE PRODUCTION
COMMERCE
BUREAUX - SALLES
JARDINS - GARDENS
RECYCLAGE
PROVISOIRES
ABRIS TOITURES
COURS
HALLES EN PREAU
HALLES ADOSSEES













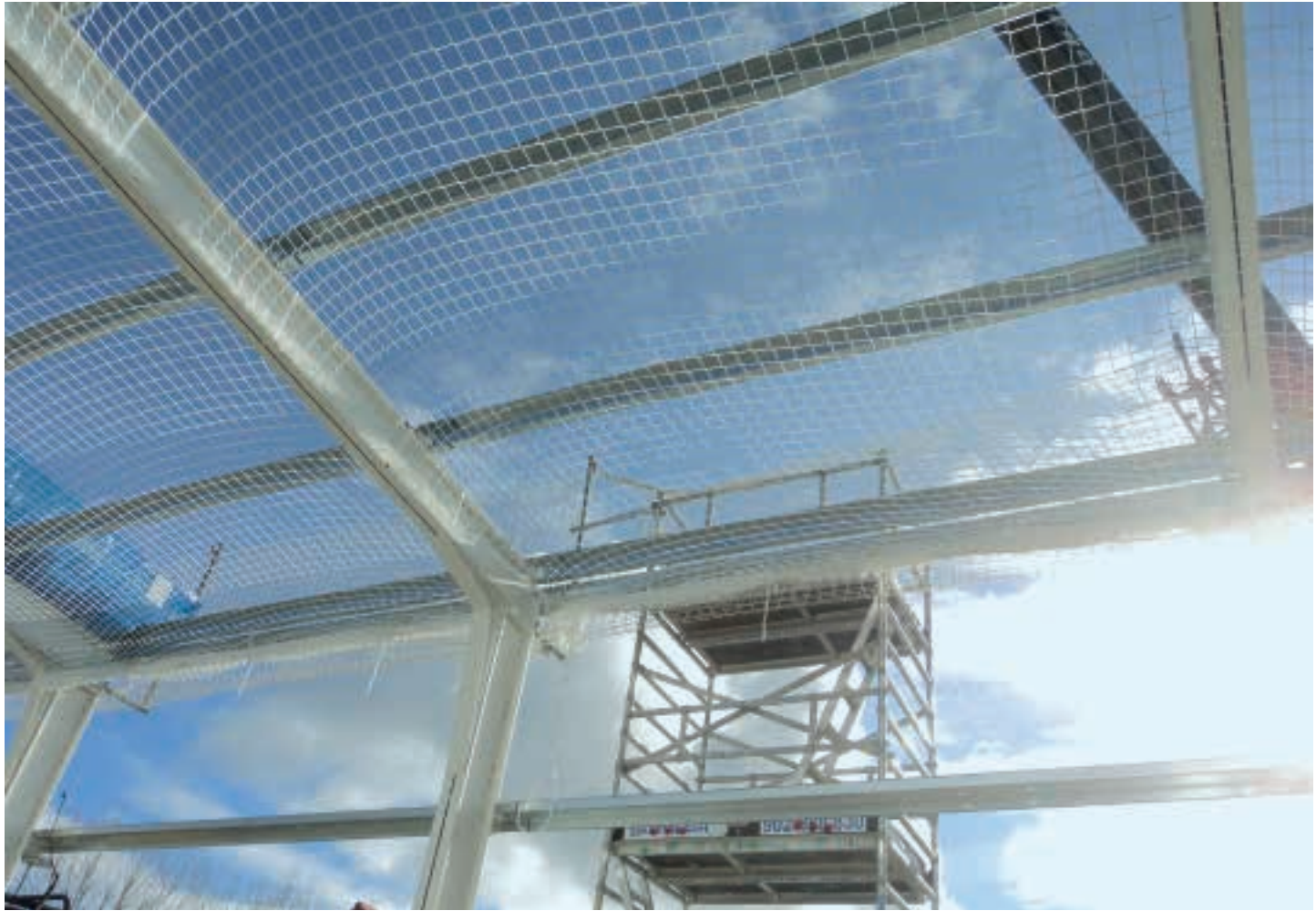

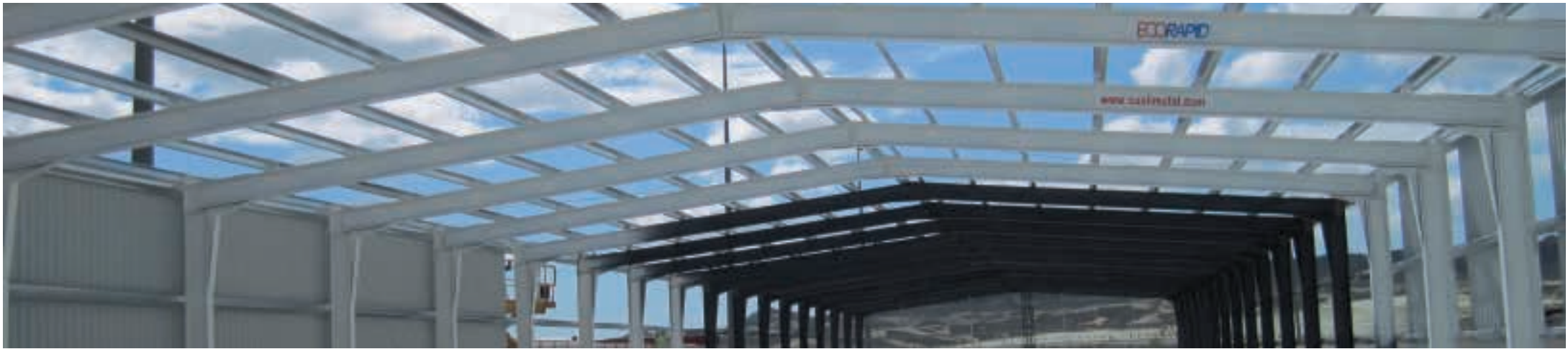





MECARAPID[®]

CUALIMETAL

Hall et entrepôts modulaires diaphanes

Les halls MECARAPID[®] permettent de couvrir des jours diaphanes Supérieurs à ceux du système ECORAPID[®], avec la polyvalence de halls "sur mesure" ou de halls industriels conventionnels.

Ils se composent de structure métallique modulaire préfabriquée, qui incorpore le type de couverture et de façades dont le client a besoin, et constituent le hall idéal pour chaque besoin.

- Jusque 40 m de largeur libre de hall.
- Sans limite de hauteur et de longueur.
- Structure à une ou deux pentes.

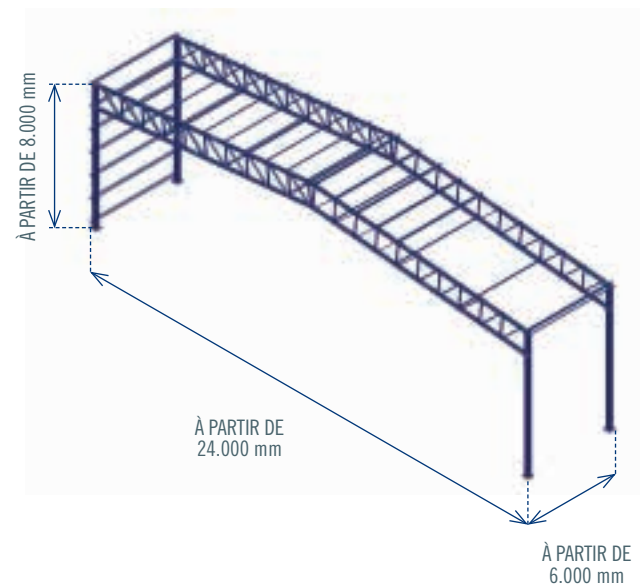
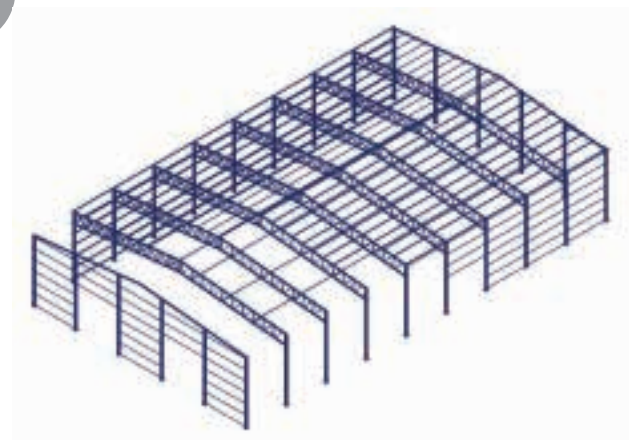

Gamme de couleurs disponible





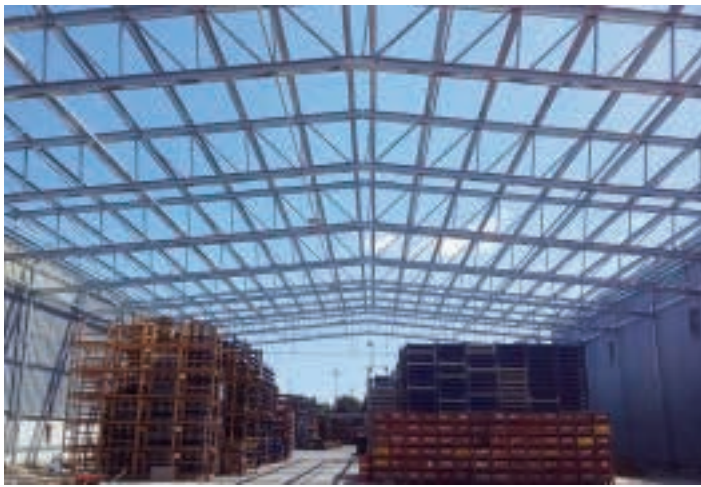





PLENAVE[®]

CUALIMETAL

Solutions modulaires pliantes

Facilement démontable et totalement récupérable, composée de l'union de modules indépendants dont la structure est formée de portiques fabriqués avec des profilés galvanisés formés à froid.

Cette solution incorpore un système optimal de montage de hall-entrepôt et donne une réponse de construction immédiate en quelques heures à peine, satisfaisant ainsi les besoins du marché en matière de montage urgent inégalable avec la technologie actuelle.

Son exécution imminente en fait un produit idéal pour entrepôts et bâtiments en général à usage temporaire ou permanent, offrant la même qualité que le reste de nos constructions modulaires.

Un segment important de son marché est constitué par l'achat pour ensuite le destiner à la location.

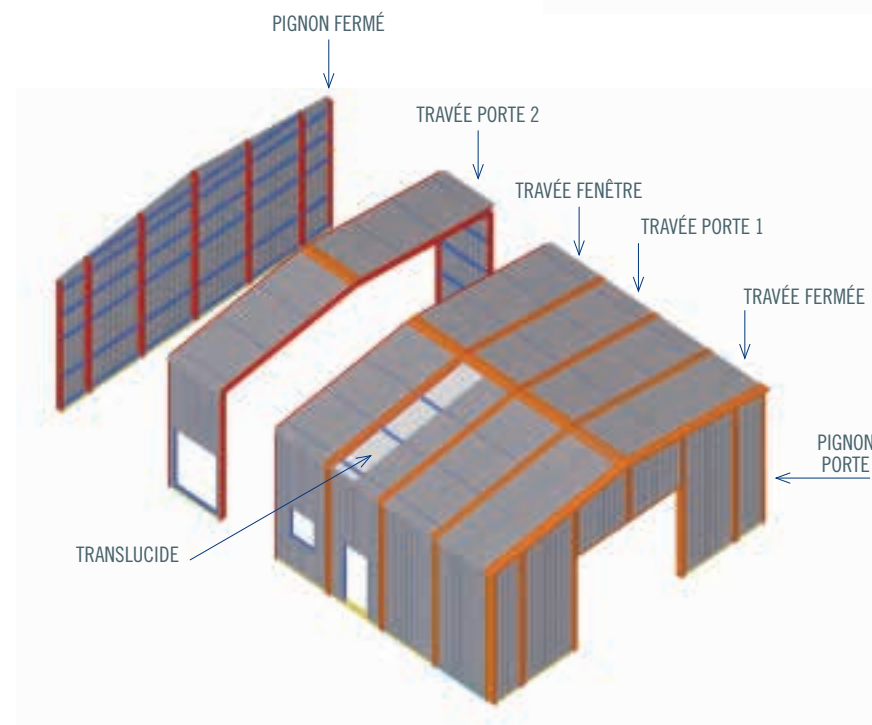

Nous avons développé 7 modèles aux dimensions standard qui pourront s'adapter à tous les besoins. Ces modules peuvent incorporer sur le côté, des portes et des fenêtres; il existe 4 types de modules pour chacun des 7 modèles: module fermé. Porte piétonnière à un battant, porte piétonnière à 2 battants et fenêtre.

PLENAVE® 7.3

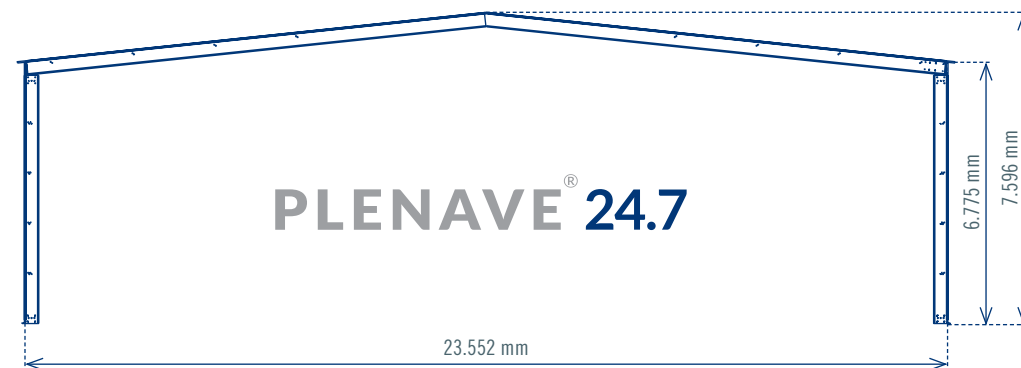
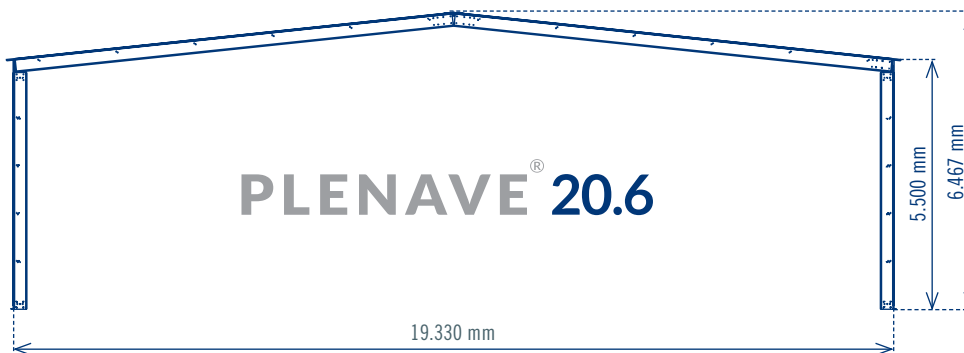
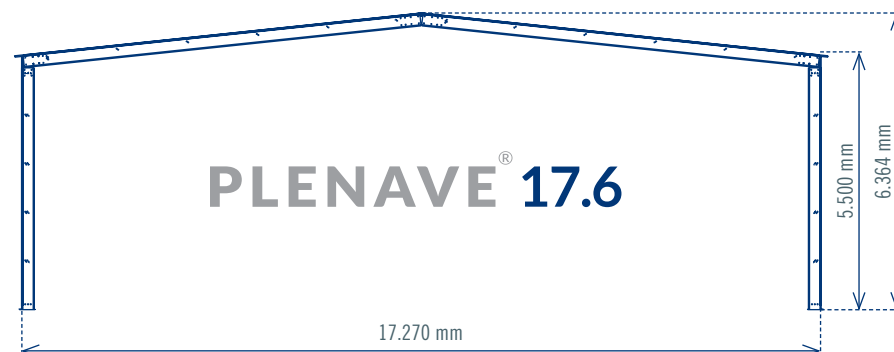
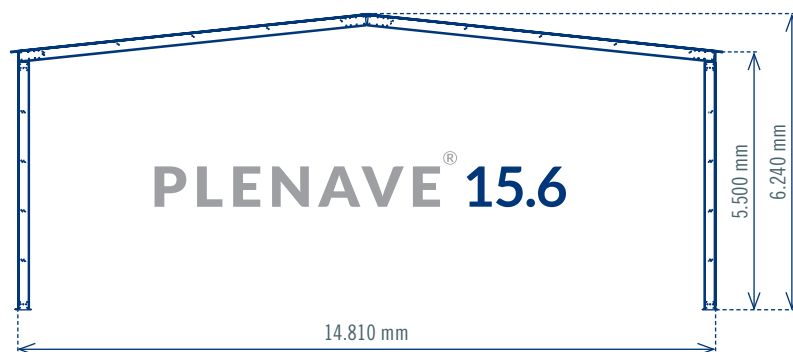
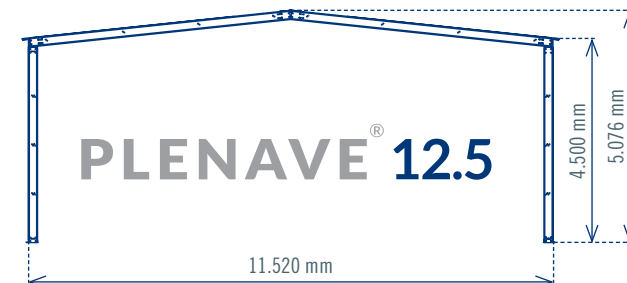
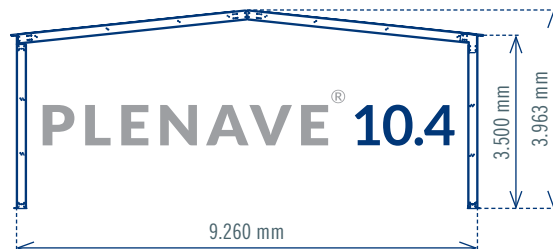
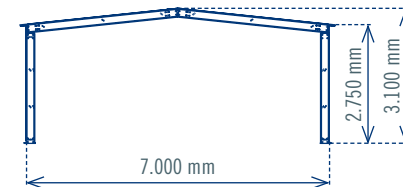











NAVERAPID[®]

CUALIMETAL

Alternative pour les ponts roulants

Halls diaphanes de 24 m de large offrant la possibilité d'atteindre des hauteurs ou des charges supérieures à celles du système ECORAPID[®]. Sa structure est composée de linteaux légers formés à froid et de piliers stratifiés à chaud (profilés standardisés) avec finition galvanisée; c'est, par ailleurs, un système compatible avec l'installation de ponts roulants.

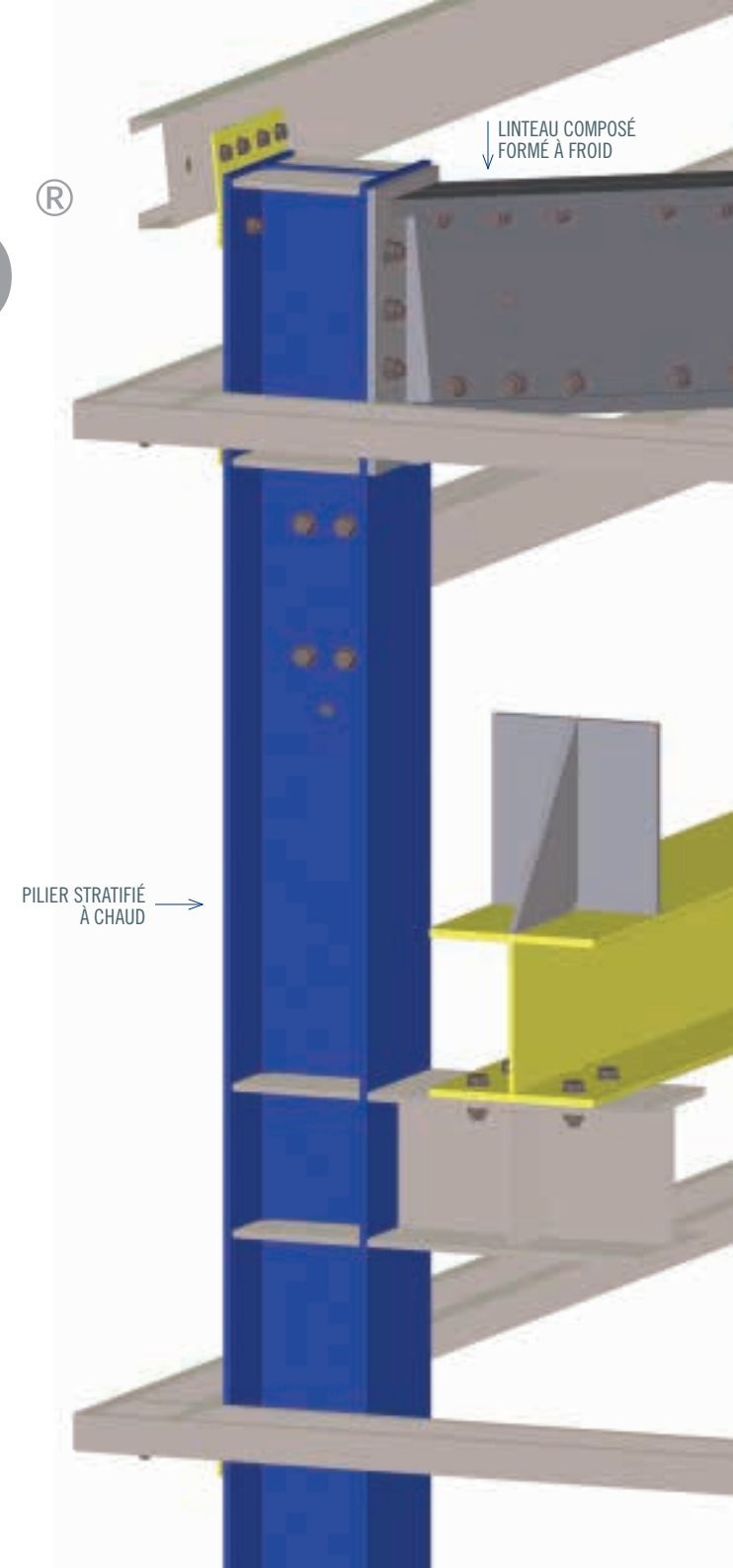



NAVEXPRESS[®]

CUALIMETAL

La meilleure solution pour garages, débarras ou petits ateliers

Modèle similaire à l'ECORAPID[®], de taille réduite et dimensions standard (3 m de large x 5 m de long, 4 m de large x 8 m de long, 5 m de large x 10 m de long) afin que le montage puisse être exécuté par le client.





MARQUISOL[®]

CUALIMETAL

Abri métallique modulaire

Développé dans le but de satisfaire facilement les besoins des clients, de façon peu coûteuse et rapide. Il convient de souligner sa conception innovante et la fonctionnalité de son pilier incliné qui facilite l'accès des véhicules.

Les profilés formés à froid comme ceux des éléments d'union des différentes parties reçoivent un traitement de galvanisation qui apporte une plus grande résistance aux agents extérieurs par rapport à la corrosion, garantissant ainsi une conception durable dans le temps.

A partir d'un module initial d'une capacité pour deux véhicules, il est possible d'augmenter le nombre de modules nécessaires jusqu'à obtenir les places souhaitées.

En guise de couverture, une tôle ondulée mini onde peut être utilisée et offre un design attrayant. Cette couverture qui peut être posée de chaque côté, est susceptible d'utiliser d'autres modèles de tôle, des panneaux photovoltaïques, etc. pour s'adapter aux exigences du client.

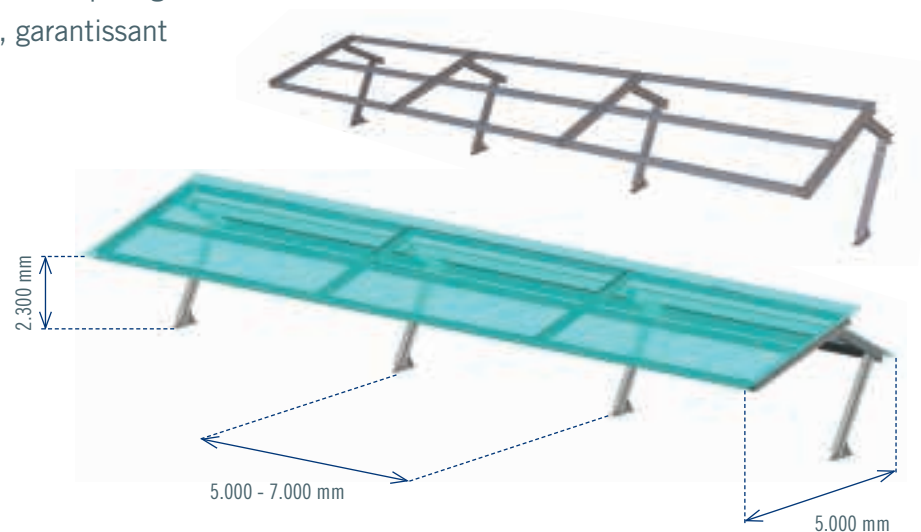

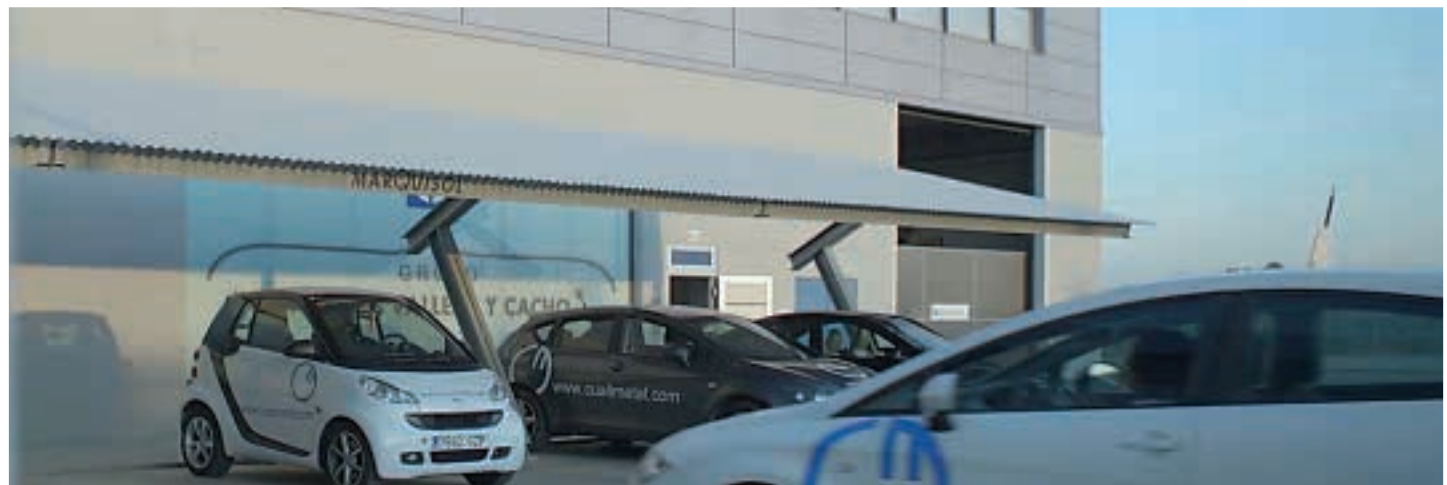



Nous adaptons des solutions optimales en conception, ingénierie, construction et fabrication, conformes aux besoins du client.

Des halls sur mesure

Notre équipe d'ingénierie et fabrication développe des halls en fonction des besoins stratégiques et opérationnels de nos clients.

Grands jours, hauteurs spéciales, structures singulières, halls de grandes dimensions ou tout autre besoin de construction que ces derniers peuvent demander.

Nos projets et l'efficacité de construction de nos halls nous cautionnent.

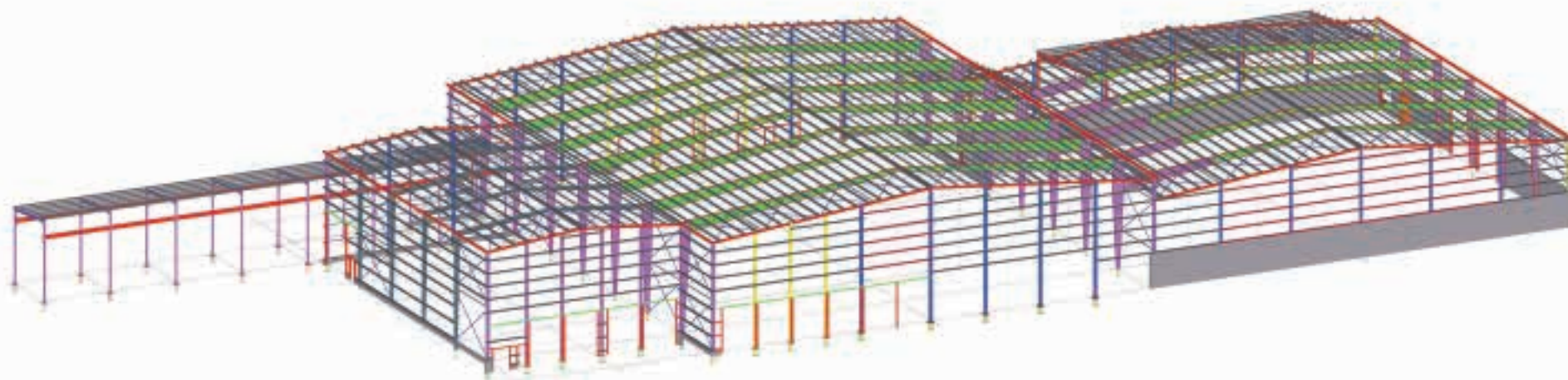







Connaissance, travail, engagement, créativité et notre propre méthode nous ont transformés en une organisation capable de relever tous les challenges, n'importe où, n'importe quand.



Secteurs

La fiabilité des solutions **CUALIMETAL, S.A.U.** pour halls industriels à usage temporaire comme permanent et leur durabilité font que nos halls soient installés dans de nombreux secteurs industriels et bâtiments emblématiques comme les pavillons des parcs d'expositions et enceintes sportives.

Voici quelques-uns des secteurs où nous sommes présents.

Industriel

Logistique

Recyclage

Automobile

Agricole

Aéronautique

Bureaux

Centres de Sports

Constructions Temporaires



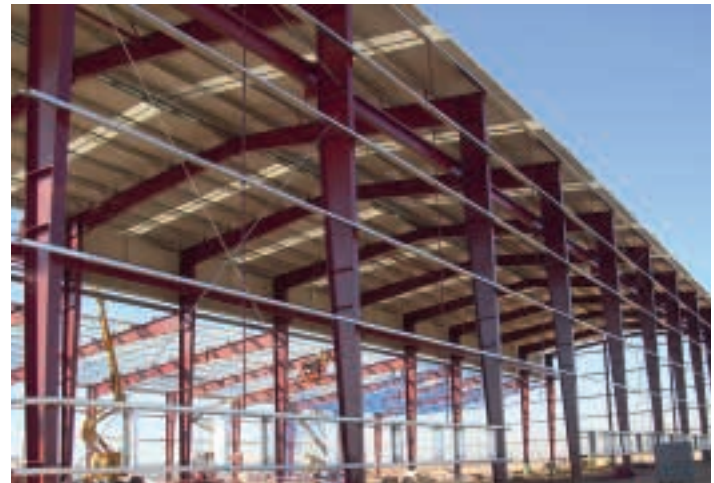



Logistique









Recyclage

















Aéronautique





Bureaux









Centres de Sports





Constructions Temporaires











SIEGE

Parque Empresarial Puerta Norte, Calle J.

Ctra. N-330, Salida 509. 50820 Zaragoza (ESPAGNE)

Tel. (+34) 976 348 282 Fax (+34) 976 314 302

www.cualimetal.com



www.cualimetal.com