



Enter the "Microscopy University" on the web and discover a whole new world.

MicroscopyU

<https://www.microscopyu.com>

Nikon's International Small World Photomicrography Competition



<https://www.nikonsmallworld.com>

N.B. Export of the products* in this brochure is controlled under the Japanese Foreign Exchange and Foreign Trade Law. Appropriate export procedure shall be required in case of export from Japan.
*Products: Hardware and its technical information (including software)

Monitor images are simulated.
Company names and product names appearing in this brochure are their registered trademarks or trademarks.

Specifications and equipment are subject to change without any notice or obligation on the part of the manufacturer. January 2023
©2005-23 NIKON CORPORATION

WARNING TO ENSURE CORRECT USAGE, READ THE CORRESPONDING MANUALS CAREFULLY BEFORE USING YOUR EQUIPMENT.



NIKON CORPORATION

Shinagawa Intercity Tower C, 2-15-3, Konan, Minato-ku, Tokyo 108-6290, Japan
phone: +81-3-6433-3705 fax: +81-3-6433-3785
<https://www.healthcare.nikon.com/en/>



Nikon Instruments Inc.

1300 Walt Whitman Road, Melville, N.Y. 11747-3064, U.S.A.
phone: +1-631-547-8500; +1-800-52-NIKON (within the U.S.A. only)
fax: +1-631-547-0299
<https://www.microscope.healthcare.nikon.com/>

Nikon Europe B.V.

Stroombaan 14, 1181 VX Amstelveen, The Netherlands
phone: +31-20-7099-000
https://www.microscope.healthcare.nikon.com/en_EU/

Nikon Precision (Shanghai) Co., Ltd.

CHINA phone: +86-21-6841-2050 fax: +86-21-6841-2060
(Beijing branch) phone: +86-10-5831-2028 fax: +86-10-5831-2026
(Guangzhou branch) phone: +86-2-3882-0551 fax: +86-2-3882-0580
https://www.microscope.healthcare.nikon.com/zh_CN/

Nikon Canada Inc.

CANADA phone: +1-905-625-9910 fax: +1-905-602-9953

Nikon France, Succursale de Nikon Europe B.V.

FRANCE phone: +33-1-4516-4516

Nikon Deutschland, Zweigniederlassung der Nikon Europe B.V.

GERMANY phone: +49-211-9414-888

Nikon Italy, Branch of Nikon Europe B.V.

ITALY phone: +39-055-300-9601

Nikon Europe B.V., Amstelveen, Zweigniederlassung Schweiz (Egg/ZH)

SWITZERLAND phone: +41-43-277-2867

Nikon UK, Branch of Nikon Europe B.V.

UNITED KINGDOM phone: +44-208-247-1717

Nikon Österreich, Zweigniederlassung der Nikon Europe B.V.

AUSTRIA phone: +43-1-972-6111

Nikon Singapore Pte. Ltd.

SINGAPORE phone: +65-6559-3651 fax: +65-6559-3668

Nikon Australia Pty Ltd

AUSTRALIA phone: +61-2-8767-6900

Nikon Instruments Korea Co., Ltd.

KOREA phone: +82-2-6288-1900 fax: +82-2-555-4415

Biological Microscopes



Contents

	Motorized Focusing	Brightfield	Darkfield	DIC	Phase Contrast	Polarizing	Epi-fluorescence	Additional Features	Page
Super Resolution Microscopes									3
Inverted Microscopes									
Ti2-E	✓	LED/100W	✓	✓	✓		✓	NAMC*1	4
Ti2-A		LED/100W	✓	✓	✓		✓	NAMC	4
Ti2-U		LED/100W	✓	✓	✓		✓	NAMC	4
Ts2R-FL		LED		✓	✓		✓	Emboss*2/ NAMC/Spindle	5
Ts2R		LED		✓	✓			Emboss/ NAMC/Spindle	5
Ts2-FL		LED			✓		✓	Emboss	5
Ts2		LED			✓			Emboss	5
Cell Screening									
BioStudio-T	Option	LED			✓				7
BioStudio-mini		LED			✓				7
Upright Microscopes									
Ni-E (focusing stage)	✓	100W	✓	✓	✓	Simple	✓		8
Ni-E (focusing nosepiece)	✓	100W	✓	✓			✓		8
Ni-U		LED/100W	✓	✓	✓	Simple	✓		8
Ci-E		LED	✓		✓	Simple	✓	Motorized nosepiece	9
Ci-L plus		LED	✓		✓	Simple	✓	LIM feature	9
Ci-S		30W	✓		✓	Simple	✓		9
Si		LED	✓		✓	Simple	Dia-fluorescence	LIM feature	9
Ei		LED							10
Polarizing Microscopes									
LV100N POL		50W*3				✓			10
Ci-POL		30W				✓			10
E200POL		30W				✓			10
Microscope for Asbestos Identification									
LV100ND POL/DS		50W*3			Dispersion Staining				11
Fixed Stage Microscope for Electrophysiological Research									
FN1		100W		✓			✓		11
Stereo Microscopes									12
Confocal Microscopes									14
Cameras									15
Software									16
Objectives									18
Combinations of DIC Prisms and Objectives									20
Epi-fluorescence Filter Cubes									21
Dimensional Diagrams									22

*1 NAMC (Nikon Advanced Modulation Contrast) is Nikon's unique modulation contrast observation method, which provides stereoscopic images similar to DIC observation, even with samples on plastic dishes.
*2 Emboss contrast is Nikon's unique contrast observation method. It provides pseudo-three-dimensional images using focal illumination, which gives high contrast to samples. *3 Brighter than 100W

Super Resolution Microscopes

Super Resolution Microscope

N-SIM S

Achieving temporal resolution of up to 15 fps and twice the spatial resolution of conventional light microscopes enables fast super-resolution imaging of dynamic live cell events

- The unique high-speed structured illumination system enables high-speed super-resolution imaging at 15 fps (2D-SIM mode, 512 x 512 pixels, 2 msec exposure time)
- Utilization of "Structured Illumination Microscopy" technology achieves nearly twice the resolution of conventional light microscopes (up to approx. 115 nm when excited with 488 nm laser in 3D-SIM mode)
- Automated optimization of structured illumination patterns for different wavelengths and magnifications enables fast 2-color TIRF-SIM imaging
- The large imaging area of up to 66 square μm enables high throughput for applications/samples that benefit from larger FOV, such as a neurons
- The optional two-camera imaging adapter allows simultaneous two-wavelength super-resolution imaging with excitation of 488 nm and 561 nm
- The personal super-resolution microscope N-SIM E, which provides a streamlined, affordable super-resolution system supporting only essential, commonly used excitation wavelengths and imaging modes, is also available

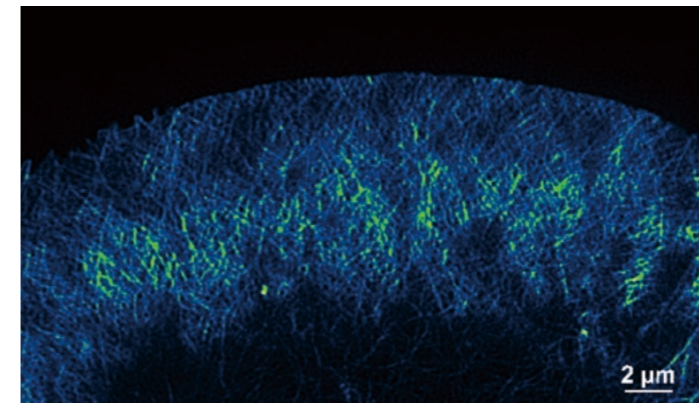

Growth cone of NG108 cell labeled with GFP-Lifeact for F-actin.
Image courtesy of: Drs. Minami Tanaka and Kaoru Katoh, The National Institute of Advanced Industrial Science and Technology (AIST)

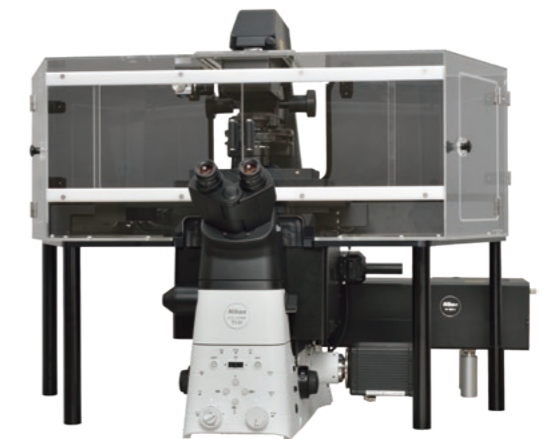

Super Resolution Microscope

N-STORM

Resolution 10 times that of conventional light microscopes enables a greater understanding at the molecular level

- Ultra-high spatial resolution (up to 20 nm in xy) is achieved by utilizing accurate localization information of thousands of discrete fluorophore molecules within a specimen
- A tenfold enhancement has also been achieved in axial resolution (up to 50 nm)
- Multicolor super-resolution imaging utilizing both activator-reporter pairs and activator-free labels affords a critical insight into the localization and interaction of proteins at the molecular level
- The N-STORM 5.0, the newest version of N-STORM, is capable of more flexible imaging sequencing thanks to improved JOBS function

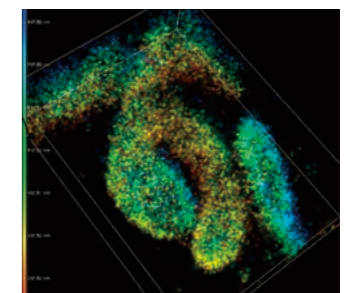

Tom 20 of Mitochondria labeled with Alexa Fluor® 647

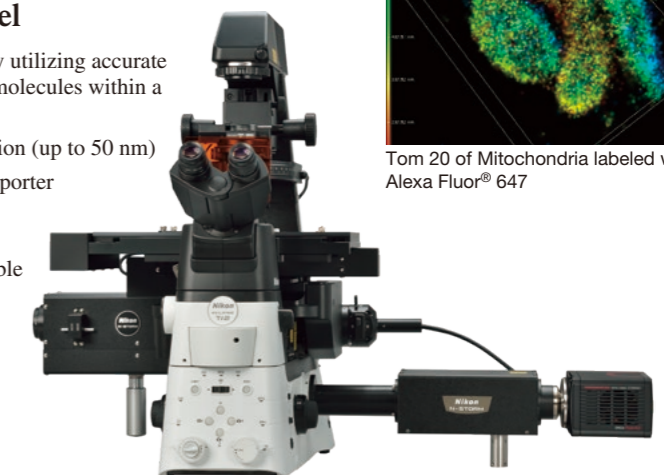

Inverted Microscopes

Inverted Research Microscopes

ECLIPSE Ti2-E/Ti2-A/Ti2-U

Leading platform for advanced imaging

- Bright and uniform illumination is provided across an unprecedented 25 mm field of view that maximizes the sensor area of large-format CMOS cameras, and significantly improves data throughput
- Ti2-E is a motorized and intelligent model for advanced imaging applications, and Ti2-A and Ti2-U are manual models with imaging capability for laser applications. Ti2-A has unique, intelligent features
- Ti2-E is compatible with real-time focus maintenance Perfect Focus System (PFS), auto correction collar, and external phase contrast system
- For its stable and drift-free platform, Ti2-E is perfect for super-resolution and confocal imaging
- The hardware-triggering capabilities of Ti2-E enhance even the most challenging, high-speed imaging applications
- Stability of PFS on Ti2-E is enhanced by reducing mechanical load on the nosepiece. It is compatible with broad wavelengths from ultraviolet to infrared, as well as various applications involving plastic dishes, single molecule and multi-photon imaging
- Ti2-E/Ti2-A's intelligent functions provide interactive guidance for microscope operation by integrating data from internal sensors, thus eliminating the possibility of user errors. The status of each sensor is automatically recorded during image acquisition
- The Water Immersion Dispenser automatically applies the appropriate amount of water to the tip of an objective, eliminating evaporation and overflow during experiments



Illumination modules

Ti2-LAPP Modular Illumination System (for Ti2-E/A/U)

A wide range of illumination modules can be flexibly combined or added to create an imaging system tailored for individual research. Utilizing the Ti2's stratum structure, up to five modules can be simultaneously mounted and rapidly switched. Dual layer configuration of filter cube turrets enables optimal filter configuration for illumination modules on each layer.

- 1 EPI-FL Module for Large FOV: Delivers a large 25 mm field of view and is perfect for epi-fluorescence imaging with cameras with large sensors
- 2 H-TIRF Module: Enables automatic laser focus adjustment and incident angle adjustment for TIRF observations
- 3 N-STORM Module2: Equipped with motorized switching of illumination field for N-STORM microscopy
- 4 DMD Module: Allows for simultaneous multi-point photoactivation with customizable illumination ROIs
- 5 XY Galvano Scanning Unit: Allows for simultaneous photostimulation and confocal imaging with AX/AX R

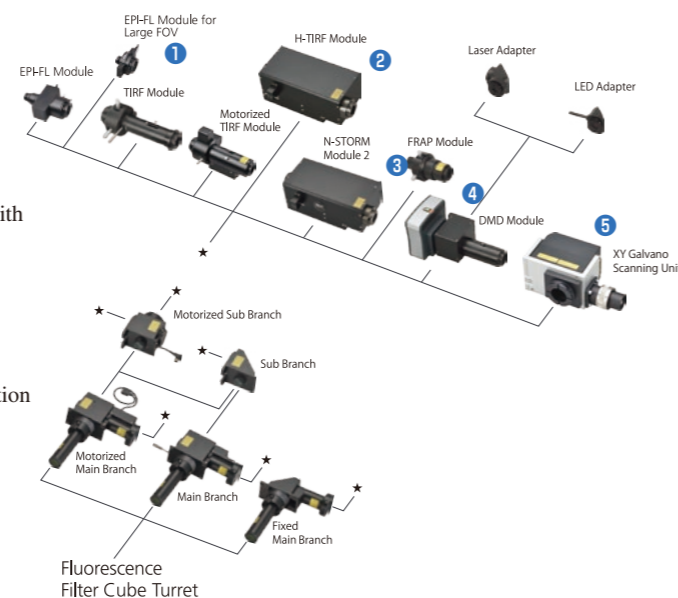

Inverted Microscopes

Inverted Research Microscopes

ECLIPSE Ts2R/Ts2R-FL

A compact inverted research microscope configurable with a wide variety of observation methods

- Space-saving compact body allows these models to be easily fit inside a laminar flow hood
- Low stage design helps reduce fatigue during repetitive sample exchange
- Mechanical stage with long travel stroke enables observation of entire 96-well plates
- High-intensity LED light source is used for both diascopic and epi-fluorescence illumination
- In addition to DIC and NAMC, the Emboss Contrast method is possible, enabling observation of thick samples with high contrast and relief images using standard condenser lenses and objectives, supporting both plastic and glass dishes
- The Ts2R-FL features built-in fluorescence light source and filter turret, accommodating up to four sets of LED units and filter cubes
- Illumination can be switched to epi-fluorescence with one button; the fluorescence illumination brightness adjuster is located on the same side of the microscope for intuitive operation (Ts2R-FL)
- Optional Contrast Shield blocks room light, making high S/N fluorescence observation possible even in brightly-lit rooms (Ts2R-FL)
- The spindle observation system allows accurate locating of spindle bodies, which is important for ICSI, and also makes switching to NAMC and emboss contrast observation easy



ECLIPSE Ts2R
(Diascopic illumination model)



ECLIPSE Ts2R-FL
(Diascopic and epi-fluorescence illumination model)

Inverted Routine Microscopes

ECLIPSE Ts2/Ts2-FL

Fits in every laboratory — Simple to use and compact

- Space-saving compact bodies allow these models to be easily located next to incubators; camera port located on the side enables confirmation of what is on the stage from the observation position
- Mechanical stage with long travel stroke enables observation of entire 96-well plates
- High-intensity LED light source is used for both diascopic and epi-fluorescence illumination
- The Emboss Contrast method allows observation of thick samples with high contrast and relief images using standard condenser lenses and objectives, supporting both plastic and glass dishes
- The Ts2-FL features built-in fluorescence light source and filter turret, accommodating up to three sets of LED units and filter cubes
- Illumination can be switched to epi-fluorescence with one button; the fluorescence illumination brightness adjuster is located on the same side of the microscope for intuitive operation (Ts2-FL)
- Optional Contrast Shield blocks room light, making high S/N fluorescence observation possible even in brightly-lit rooms (Ts2-FL)



ECLIPSE Ts2
(Diascopic illumination model)



ECLIPSE Ts2-FL
(Diascopic and epi-fluorescence illumination model)

LED Illumination System for Fluorescence Microscopy

D-LEDI

(for Ti2-E/A/U, Ts2R-FL, Ni-E/U, Ci-E/Ci-L plus/Ci-S, FN1)

A long-life, alignment-free light source that can be attached directly to an epi-fluorescent attachment. Equipped with 385 nm, 475 nm, 550 nm and 621 nm LEDs, multiple wavelengths can be turned on or off at the same time. Excitation and image acquisition can be synchronized using NIS-Elements imaging software.



Micromanipulator System

NTX (for Ti2-E/A/U, Ts2R/Ts2R-FL)

The NTX with compact and easy-to-assemble design ensures stable and smooth operation without needle drift. It provides microscopic and precise specimen micromanipulation in the fields such as ICSI (Intracytoplasmic Sperm Injection) and transgenic biotechnology.

(Manufactured by NARISHIGE LIFEMED CO.,LTD.)

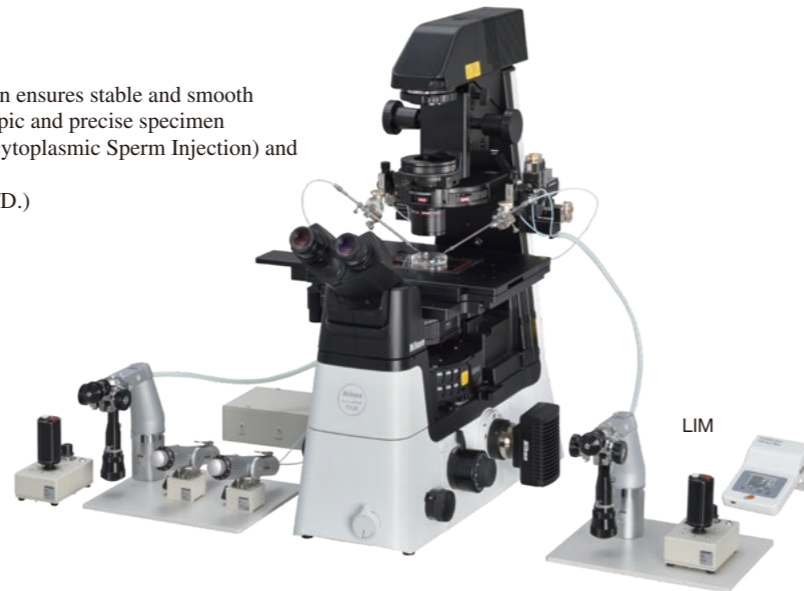

Stage Top Incubator® STX series

(for Ti2-E/A/U, Ts2R/Ts2R-FL)

It sustains the internal temperature at 37°C with humidity of 90% and CO₂ of 5% to keep the specimen in a stable and precise condition for over 1 week.

(Manufactured by Tokai Hit Co., Ltd.)



ThermoPlate® TPi series

(for Ti2-E/A/U, Ts2R/Ts2R-FL, Ts2/Ts2-FL)

Automatic thermocontrol system with a glass heating plate keeps the specimen at a set temperature. Temperature is adjustable from room temperature to 60°C in 0.1°C increments.

(Manufactured by Tokai Hit Co., Ltd.)



Cell Screening

Cell Observation Device

BioStudio-T

Vibration-free, compact phase-contrast cell observation device

- The internal optics can be moved so that an entire well plate of 124 mm (X) x 100 mm (Y) can be imaged without moving the sample. This enables vibration-free long-term time-lapse imaging and large image stitching (tiling)
- Because the BioStudio-T is waterproof and chemical-resistant, it can be decontaminated using hydrogen peroxide gas or UV sterilization. This allows it to be installed in a variety of isolators, incubators, and biosafety cabinets
- Only cell-friendly red LED illumination is turned on during image acquisition
- Equipped with motorized focusing. Operation and image acquisition are performed from a personal computer, with easy-to-use settings
- Compatible with a variety of phase contrast objectives, multi-well plates and other culture vessels



Cell Observation Device

BioStudio-mini

Compact and lightweight phase-contrast cell observation device

- Because the BioStudio-mini is waterproof and chemical-resistant, it can be decontaminated using hydrogen peroxide gas or UV sterilization. The compact footprint allows it to be installed in a variety of isolators, incubators, and biosafety cabinets
- Only cell-friendly red LED illumination is turned on during image acquisition
- Image acquisition is performed from a personal computer, with easy-to-use settings. Focusing is manual, and a motorized focusing unit and a manual stage are available as options



Upright Microscopes

Motorized Advanced Research Microscope

ECLIPSE Ni-E (focusing stage model and focusing nosepiece model)

Automated imaging capability for most advanced observations

- High-precision motorized focusing supports automated Z-series acquisition
- Observation method can be changed using buttons on the microscope body. Microscope settings are automatically set to optimal positions according to selected magnification
- Various motorized accessories can be attached
- Stratum structure allows double-layer mounting of a laser photoactivation device and an epi-fluorescence attachment to enable simultaneous photoactivation and imaging
- Focusing stage or focusing nosepiece is selectable as the focusing mechanism
- High optical performance: uniform and bright illumination using fly-eye optics
- Built-in, easy-to-reach image capture button. Angled operation buttons allow touch-type operations during observation



Ni-E (Focusing stage) configured with motorized epi-fluorescence illuminator, motorized condenser and motorized quadrocular tilting tube and the DS-Fi3 camera



Ni-E (Focusing nosepiece) configured with motorized stage, motorized epi-fluorescence illuminator, back port unit, motorized quadrocular tilting tube and two cameras

Advanced Research Microscope

ECLIPSE Ni-U

Manual microscope with flexible selection of motorized options

- Motorized nosepiece, motorized epi-fluorescence cube turret and motorized shutter can be utilized
- Stratum structure allows double layer mounting of a back port unit and an epi-fluorescence attachment to enable simultaneous multichannel imaging with two cameras
- High optical performance: uniform and bright illumination using fly-eye optics
- Built-in, easy-to-reach image capture button
- An optional LED light source for brightfield and phase contrast observation is also available.



Ni-U configured with ergonomic binocular tube

Upright Microscopes

Clinical and Laboratory Microscopes

ECLIPSE Ci-E/Ci-L plus/Ci-S

Exceptional comfort for clinical and laboratory observation

- High-luminescent eco-friendly LED (Eco-illumination) for Ci-E/Ci-L plus and halogen illumination for Ci-S
- Ci-E offers motorized magnification switching and automatic light intensity reproduction, enabling use of motorized condenser
- Ci-L plus has a Light Intensity Management (LIM) feature for automatic light intensity reproduction, and an ECO mode that automatically turns the lighting off. It is also equipped with an LCD screen that displays the magnification, illumination, etc.
- By connecting the Ci-E and Ci-L plus to an optional camera recommended by Nikon, the scale bar display is automatically adjusted to match the magnification when the nosepiece is rotated
- Angle and extension adjustable ergonomic binocular tube ensures observation with natural posture. Eye-point height can be lifted using an eyelevel riser
- Stage height can be lowered by adding a nosepiece spacer, and locked for easy refocusing. Height-adjustable stage handle. Durable, scratch-resistant ceramic-coated stage
- Built-in capture button allows easy imaging with the DS-Fi3/Digital Sight 10 camera



Ci-E configured with ergonomic binocular tube



Ci-L plus configure with ergonomic binocular tube and DSC port



Ci-S configured with ergonomic binocular tube

Clinical & Educational Microscope

ECLIPSE Si

Ergonomically designed to reduce strain on eyes and body during long-term observation

- The intelligent Light Intensity Management (LIM) feature automatically remembers and reproduces the light intensity level for each objective, maintaining the appropriate brightness when switching magnifications
- The low stage design reduces arm and shoulder fatigue when changing specimen slides
- The stopper, which sets the upper limit of the stage height, eliminates the risk of damage to the slide and objective when changing samples and focusing
- Equipped with an LCD screen that displays the magnification, illumination, etc.
- Supports various observation methods, including phase contrast and simple polarizing. The unique diascope fluorescence illumination method enables fluorescence imaging without mounting an epi-fluorescence attachment
- Online Guide, a web-based operation manual accessible on smartphones, is also available
- Features a lightweight, easy-to-carry design, and the backward-rotatable tube saves storage space



Si configured with binocular tube

Upright Microscope

Educational Microscope

ECLIPSE Ei

Stimulates intellectual curiosity and interest in science

- The dedicated CFI BE2 Plan Achromat series objective and 10X eyepiece achieve a large field of view of 20 mm
- Simple and intuitive markings, such as illustrations and color-coding, enable quick understanding of the microscope operations
- Online Guide, a web-based operation manual accessible on smartphones, is also available
- A camera can be mounted on the Ei trinocular tube set. The optional Digital Sight 1000 microscope camera enables specimen images to be easily captured and shared in real time on a monitor or network
- Features a lightweight, easy-to-carry design, and the backward-rotatable tube saves storage space



Ei binocular set

Microscope for Asbestos Identification

Polarizing/Dispersion Microscope

ECLIPSE LV100ND POL/DS

Dispersion staining microscopy that aids in the identification of asbestos

- Characteristic dispersion colors of each asbestos type corresponding to the refraction index of the immersion liquid can be observed using the phase contrast condenser and objectives (10X and 40X) for dispersion staining microscopy
- Qualitative asbestos analysis is possible by determination of birefringence and elongation (positive/negative); measurement of extinction angle, refractive index, and birefringence magnitude (retardation); observation of pleochroism



Polarizing Microscopes

ECLIPSE LV100N POL/Ci-POL/E200POL

- CFI60 optics deliver world-class optical performance
- Excellent basic performance, operability, durability and, above all, outstanding image sharpness
- LV100N POL is a research polarizing microscope that boasts twice the rigidity of conventional models and a brightness exceeding 100W (12V-50W model with centering quintuple nosepiece). The built-in Fly-Eye optics ensures uniform illumination up to the edge of the field of view
- ECLIPSE Ci-POL is compact yet offers high functionality, such as a nosepiece with DIN standard compensator slot (6V-30W model with centering quintuple nosepiece). Built-in capture button allows easy imaging with the DS-Fi3/Digital Sight 10 camera
- E200POL is a cost-efficient and extremely compact model (6V-30W multi-voltage model with quadruple nosepiece)



LV100N POL (diascopic illumination type)



Ci-POL (diascopic illumination type)



E200 POL (diascopic illumination type)

Fixed Stage Microscope for Electrophysiological Research

ECLIPSE FN1

Dedicated microscope for electrophysiological research with I-shaped body design—more room for smooth electrode manipulation

- The 40X and 60X objectives allow crisp high resolution IR-DIC imaging by correcting axial chromatic aberration up to near-IR light (850 nm)
- The 100X objective with 1.1 NA and 2.5 mm working distance comes with a correction function for depth- and thermally-induced aberrations
- The vertical motion nosepiece enables magnification changes without moving Petri dish (15 mm or less in height)
- Easy switching between IR light and reflected illumination
- With an optional variable magnification double port (0.35X, 2X, 4X), both wide field and high magnification observations can be carried out with a 16X objective alone



All objectives have wide approach angles and long working distances (45° and 3.5 mm with 40X objective).



Configuration with Narishige micromanipulators and epi-fluorescence attachment

Stereo Microscopes

SMZ25/SMZ18

- Motorized zoom model SMZ25 is the first stereo microscope to offer a large 25:1 zoom ratio. Zoom ratio of manual zoom model SMZ18 is 18:1
- Optical path of both eyes boast high NA of up to 0.156 with the SHR Plan Apo 1X objective and SMZ25 zooming body
- Fly eye lens employed in the epi-fluorescence attachment ensures uniform brightness over the entire field of view even at the lowest magnifications
- Motorized focus and zoom operation (SMZ25)
- User-friendly remote control (SMZ25)
- Total magnification 3.15-315X (SMZ25), 3.75-270X (SMZ18), depending on objective used
- Compatible with various accessories including trinocular tubes



SMZ25 configured with motorized epi-fluorescence attachment and LED diascope illumination base



SMZ18 configured with LED diascope illumination stand

Accessories for SMZ25/SMZ18

LED Diascopic Illumination Base

The slim LED DIA Base is equipped with OCC illumination, which utilizes oblique lighting to enable high-contrast illumination of colorless and transparent specimens.



Fiber Diascopic Illumination Base

The Fiber DIA base features condenser lenses that can be switched between low and high magnifications. Furthermore, the OCC illumination system allows high-contrast illumination.

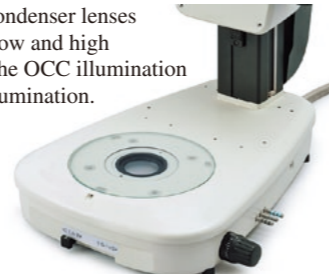

LED Ring Illumination Unit

LED Ring Illumination Unit is equipped with high-intensity, long-life (20,000 hours) LEDs. The illuminator's dial adjusts the intensity of the white LED.



LED Dark Field Unit

Darkfield observation is possible simply by attaching the darkfield unit to the base.

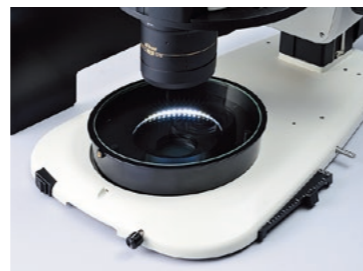

Simple Polarizing Attachment

The analyzer is attached to the objective and the polarizer to the base or stand to enable polarized observations.

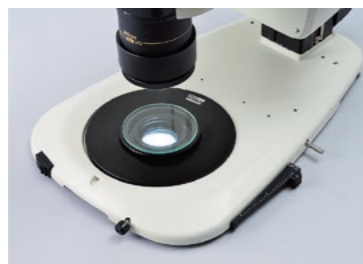

Epi Fluorescence Attachment

A fly eye lens ensures bright high-contrast images over the entire field of view. A motorized model with control via a remote control unit or imaging software is also available.



Stereo Microscopes

SMZ1270/1270i, SMZ800N

- SMZ1270/1270i provides highest-in-class zoom ratio of 12.7:1. Zoom ratio of SMZ800N is 8:1
- Total magnification 3.15-480X (SMZ1270/1270i), 5-480X (SMZ800N), depending on eyepieces and objectives used
- High-level chromatic aberration correction provides sharp images
- Automatic detection of zoom magnification in combination with the NIS-Elements software. Objective information is also detected with the intelligent nosepiece. (SMZ1270i)
- Compatible with various accessories, including trinocular tubes, epi-fluorescence attachment and teaching head. The slim-type LED diascope stand is equipped with OCC illumination. The nosepiece offers both a widened magnification range and on-axis imaging



SMZ1270 configured with binocular tube and LED diascope illumination stand



SMZ1270i configured with trinocular tilting tube, intelligent nosepiece and LED diascope illumination stand



SMZ800N configured with binocular tube and plain stand

SMZ745/SMZ745T

- Total magnification 3.35-300X
- Zoom ratio 7.5:1
- Compatible with a camera (SMZ745T)
- Eyepiece inclination 45°



SMZ745T configured with C-PS plain stand



SMZ745 configured with C-PS plain stand

SMZ445

- Total magnification 4-70X
- Zoom ratio 4.4:1
- Eyepiece inclination 45°



SMZ445 configured with hybrid LED stand

SMZ460

- Total magnification 3.5-60X
- Zoom ratio 4.3:1
- Eyepiece inclination 60°



SMZ460 configured with hybrid LED stand

Confocal Microscopes

Multiphoton Confocal Microscope

AX R MP

Provides ultrafast imaging in deeper areas, along with enhanced resolution and field of view

- The AX R MP features a field-of-view with a diagonal of 22 mm for both resonant and galvano scanners
- The galvano scanner is capable of high-resolution imaging of up to 8192 x 8192 pixels, and the resonant scanner is capable of high-resolution fast imaging of up to 2048 x 2048 pixels
- Resonant scanning allows extremely high-speed imaging (up to 720 fps at 2048 x 16 pixels)
- Dedicated motorized upright microscope provides clearance of 40 cm under the objective. A tilting nosepiece is available, allowing the sample to be observed in its natural posture
- Two types of motorized stand, a gate stand and a single stand, are selectable to accommodate different types of samples
- The new CFI75 Apochromat LWD 20XC W objective with 1.00 numerical aperture and 2.80 mm working distance provides bright images over the entire field of view



Configured with a gate stand

Configured with a single stand

Confocal based Super Resolution Microscope

AX/AX R with NSPARC

Unparalleled resolution, speed, sensitivity and field of view, with additional super-resolution capabilities

- Both the galvano scanner on the AX/AX R and the resonant scanner on the AX R have a large field of view (25 mm diagonal). This field of view is also realized with both inverted and upright microscope stands
- The AX/AX R is capable of high-resolution imaging of up to 8192 x 8192 pixels with the galvano scanner, and fast high-resolution imaging of up to 2048 x 2048 pixels with the resonant scanner
- The AX R's high speed resonant scanning allows extremely high-speed imaging (up to 720 fps at 2048 x 16 pixels)
- The NSPARC detector improves resolution and S/N ratio with an SPPC detector array that collects a two-dimensional image at each scanned point, achieving not only super resolution of 100 nm on the X and Y axes, but also super resolution of 300 nm on the Z axis
- The DUX-VB detector can custom-tune the emission bandwidth to a library of labels and probes. The DUX-ST detector allows up to 12 emission band passes, upgradable to 18. Both detectors can be customized with high sensitivity and low noise GaAsP or Multi-alkali PMT
- AI-based software tools are available, including Denoise.ai that removes noise from resonant scan images and enables fast, high-quality imaging



Configured with Ti2-E

Cameras

Digital Cameras for Microscopes

Digital Sight Series

Nikon provides digital cameras that are optimized for microscopic imaging. Users can select the most suitable camera for their samples and observation techniques.

F-mount CMOS cameras

Microscope Camera Digital Sight 10



- Equipped with a 23.90-megapixel CMOS sensor for digital SLR cameras that has been optimized for microscopes
- Fast acquisition of high-resolution images up to 6000 x 3984 pixels
- Accurate color reproduction of microscopy images with Nikon's proprietary image processing engine
- High frame rate of up to 66 fps (1920 x 1080 pixels) enables fast focusing
- Color/monochrome capture modes can be optically switched by attaching and detaching a filter

Monochrome Microscope Camera Digital Sight 50M



- Equipped with a large format 60 megapixel monochrome CMOS sensor
- Its high sensitivity, equal to a quantum efficiency of 85%, makes it ideal for quantitative analysis of fluorescence intensity changes
- Cooling mechanism allows low noise imaging with high S/N ratio
- Reliable quantitative analysis with excellent linearity
- High frame rate of up to 225.9 fps (640 x 480 pixels) enables fast focusing
- Time-lapse imaging with high temporal resolution

C-mount CMOS camera

Microscope Camera DS-Fi3



- Equipped with a high density 5.9 megapixel CMOS sensor
- Fast acquisition of high-resolution images up to 2880 x 2048 pixels
- High frame rate of up to 30 fps (1440 x 1024 pixels) enables fast focusing easy capturing of images in all types of observation methods
- Improved quantum efficiency and read noise provide fluorescence images with higher S/N ratios
- Accurate color reproduction of microscopic images with Nikon's proprietary image processing engine
- Can be directly connected to a PC via a fast USB3.0 interface

Microscope Camera Digital Sight 1000



- Equipped with a 2.0-megapixel CMOS sensor
- Can display, capture and save 1920 x 1080 pixel full HD images at 30 fps
- Can be used standalone without a PC, by simply connecting it to a full HD display and mouse
- Save the acquired images to the SD card inserted in the camera
- Simple measurement of area and distance is possible, and scale bar can be displayed

Software

Imaging Software

NIS-Elements

NIS-Elements is an integrated platform of imaging software developed by Nikon to achieve comprehensive control of microscope image capture and document data management.

NIS-Elements handles multidimensional imaging tasks flawlessly with support for capture, display, peripheral device control, and data management & analysis of images (up to six-dimensional images).

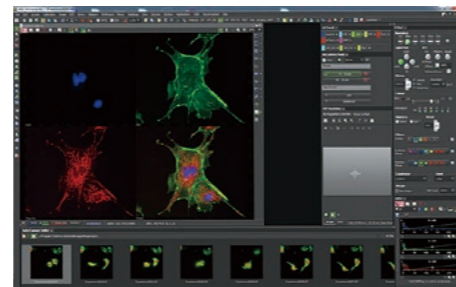

Nikon offers a number of microscope software packages to control and optimize the performance of its products.

Ar Nikon's flagship NIS-Elements package

NIS-Elements AR is optimized for advanced research applications. It features fully automated acquisition and device control through full 6D (X, Y, Z, Lambda (Wavelength), Time, Multipoint) image acquisition and analysis.

Br Standard research application package

NIS-Elements BR is suited for standard research applications. It features acquisition and device control through 4D (up to four dimensions can be selected from X, Y, Z, Lambda (Wavelength), Time, Multipoint) acquisition.

D Photodocumentation/clinical application package

NIS-Elements D supports color documentation requirements in bio-research, clinical and industrial applications, with basic measuring and reporting capabilities.

Various convenient plug-ins are available for advanced imaging and analysis capabilities.

Multidimensional Capturing

Up to 6D image acquisition combining dimensions such as X, Y, Z, time, wavelength and multipoint is easily set using the intuitive GUI.

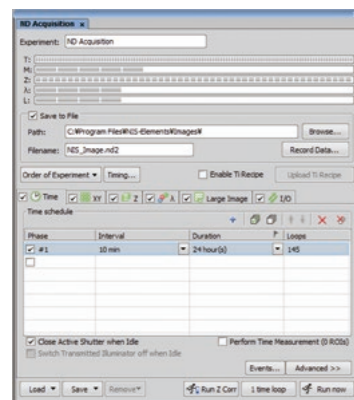

3D/2D Deconvolution

Haze and blur of the fluorescence image can be eliminated from the captured 3D image or from the 2D live preview image. (Separate plug-in for 3D and 2D)

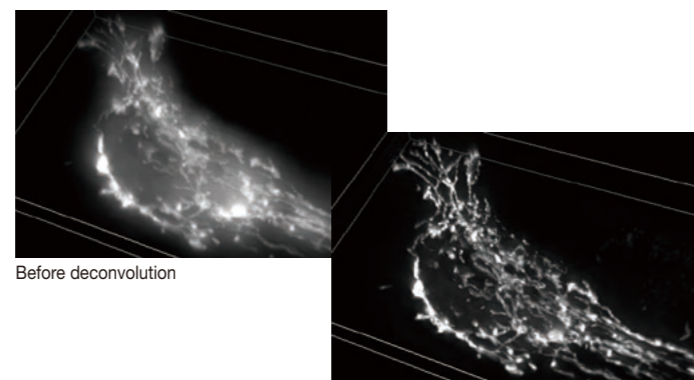

Before deconvolution

After deconvolution

Extended Depth of Focus

With the Extended Depth of Focus (EDF) plug-in, images that have been captured in a different Z-axis using a motorized stage can be used to create an all-in-focus image. Also, it is possible to create stereovision images & 3D surface images to achieve virtual 3D imaging.

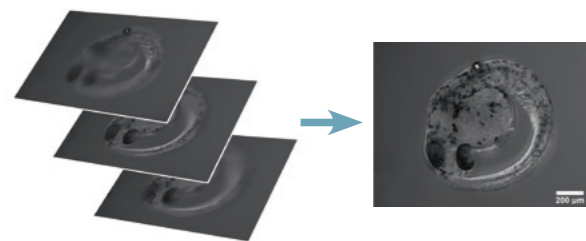

All-in-focus image created from a sequence of Z-stack images

Database

NIS-Elements has a powerful image database module that supports image and meta data. Various databases & tables can easily be created and images can be saved to the database via one simple mouse-click. Filtering, sorting and multiple grouping are also available according to the database field given for each image.

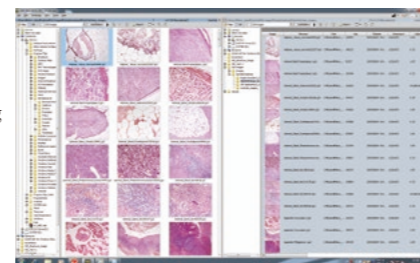

Software

L Simple imaging package

NIS-Elements L, which features a simple and user-friendly GUI, allows easy image capturing with the Digital Sight 1000, DS-Fi3, and Digital Sight 10 cameras and a tablet PC. Functions for stress-free imaging, display and measurement, including scene modes and a split-screen display, are also available.

* For information about compatible tablet PCs, contact Nikon.



Artificial Intelligence for microscopy

NIS.ai

Powerful image analysis and processing module for NIS-Elements that leverages Deep Learning and Artificial Intelligence

NIS.ai is an AI-based processing tool suite that utilizes convolutional neural networks to learn from small training datasets supplied by the user. NIS.ai includes a suite of applications for predictive imaging, image segmentation and processing.

Pre-trained AI

Clarify.ai is pre-trained to recognize fluorescence signals emitted from out-of-focus planes, and can remove the resulting haze component from fluorescence images.

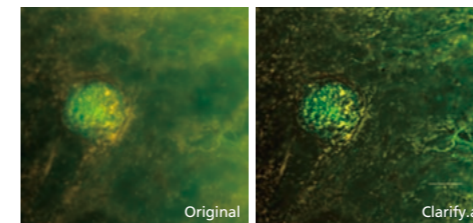

Original

Clarify.ai

Denoise.ai can recognize and remove shot noise from confocal images acquired using high-speed resonant scanners, increasing clarity.

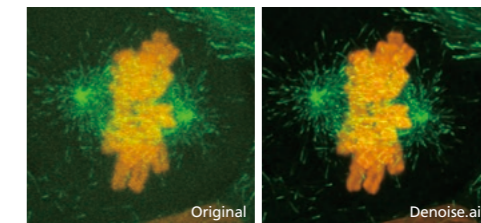

Original

Denoise.ai

User-trainable AI

Convert.ai can be trained to predict where the DAPI label would be, based on unstained images, enabling nuclear-based image analysis without staining the sample.

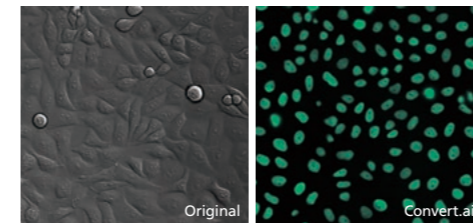

Original

Convert.ai

Segment.ai can be trained to identify and segment complex structures that are difficult to define by means of classic thresholding.

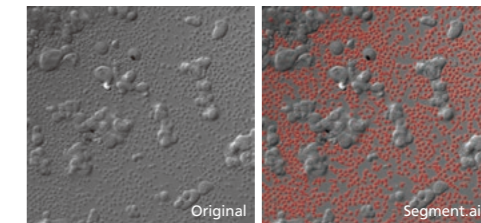

Original

Segment.ai

Enhance.ai can learn what a high signal-to-noise image looks like, and restore details in under-exposed or dim fluorescent images.

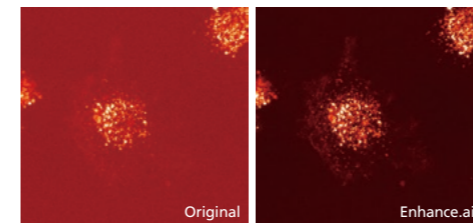

Original

Enhance.ai

Combinations of DIC Prisms and Objectives

For Ti2 and Ts2R*1 series inverted microscopes

		LWD Condenser Lens				CLWD Condenser Lens				HNA Oil Lens					
		Standard		High Contrast		High Resolution		Standard		High Resolution		Standard		High Resolution	
		Condenser Module	DIC Slider	Condenser Module	DIC Slider	Condenser Module	DIC Slider	Condenser Module	DIC Slider	Condenser Module	DIC Slide	Condenser Module	DIC Slider	Condenser Module	DIC Slider
10X	Super Fluor 10X Plan Apo Lambda D 10X	LWD N1 Dry	10X	—		—		—		—		—		—	
20X	S Plan Fluor LWD 20XC S Plan Fluor ELWD 20XC	LWD N1 Dry	20XC II	—		—		—		—		—		—	
	Super Fluor 20X Plan Fluor 20X Plan Fluor 20XC MI	LWD N2 Dry	20X	LWD N1 Dry	20X-C	—		—		—		—		—	
	Plan Apo Lambda D 20X		20X III	—		—		—		—		—		—	
Plan Apo Lambda S 25XC SII Apo LWD Lambda S 20XC WI	LWD N1 Dry	25X II 60X II-R	—		—		—		—		—		—		
40X	S Plan Fluor ELWD 40XC	LWD N1 Dry	40XC	—		—		—		—		—		—	
	Super Fluor 40XC Plan Fluor 40X Plan Apo Lambda S 40XC SII Apo LWD Lambda S 40XC WI Plan Apo Lambda D 40XC	LWD N2 Dry	40X I	LWD N1 Dry	40X I-C	—		—		—		—		—	
	Plan Fluor 40X Oil Super Fluor 40X Oil Apo Lambda S 40XC WI		40X II	—		—		—		—		—		—	
S Plan Fluor ELWD 60XC	LWD N1 Dry	60XC	—		—		—		—		—		—		
60X	Apo TIRF 60XC Oil	LWD N2 Dry	60X I	—		—		—		—		—		—	
	Plan Fluor 60XC Plan Fluor 60XS Oil		60X II	—		—		—		—		—		—	
	Plan Apo VC 60XC WI Plan Apo IR 60XC WI SR Plan Apo IR 60XC WI SR Plan Apo IR 60XC WI Plan Apo Lambda D 60X		60X IV	LWD NR Dry	60X I-R	HNA N2 Dry	60X I	HNA NR Dry	60X I-R	HNA N2 Oil	60X I	HNA NR Oil	60X I-R		
100X	HP Plan Apo VC 100X Oil SR HP Plan Apo Lambda S 100XC SII Apo TIRF 100XC Oil SR HP Apo TIRF 100XC Oil SR HP Apo TIRF 100XC Oil	LWD N2 Dry	100X I	—		—		—		—		—		—	
	Plan Fluor 100X Oil Plan Fluor 100XS Oil Plan Apo Lambda D 100X Oil		100X II	LWD NR Dry	100X I-R	HNA N2 Dry	100X I	HNA NR Dry	100X I-R	HNA N2 Oil	100X I	HNA NR Oil	100X I-R		
	Plan LWD IMSI 100XC Plan Apo VC 100X Oil*2	IMSI N2 Dry	100X III 100X I	IMSI NR Dry	100X I-R	—		—		—		—		—	

*1 Compatible with the LWD condenser lens only. Contact Nikon for information about compatible objectives.
*2 When used for IMSI

For Ni-E (focusing stage)/Ni-U upright microscopes

		Universal Condenser Dry/Motorized Universal Condenser Dry						DIC Condenser Oil			
		Standard		High Contrast		High Resolution		Standard		High Resolution	
		Condenser Module	DIC Slider	Condenser Module	DIC Slider	Condenser Module	DIC Slider	Condenser Module	DIC Slider	Condenser Module	DIC Slider
10X	Super Fluor 10X Plan Fluor 10X Plan Apo Lambda D 10X Plan Fluor 10X W	N1 Dry	10X	—		—		—		—	
20X	Super Fluor 20X Plan Fluor 20X Plan Fluor 20XC MI	N2 Dry	20X	N1 Dry	20X-C	—		—		—	
	Plan Apo Lambda D 20X		20X III	—		—		—		—	
40X	Super Fluor 40XC Plan Fluor 40X Plan Apo Lambda D 40XC Plan Apo Lambda S 40XC SII Apo LWD Lambda S 40XC WI	N2 Dry	40X I	N1 Dry	40X I-C	—		—		—	
	Apo Lambda S 40XC WI Super Fluor 40X Oil Plan Fluor 40X Oil		40X II	—		—		—		—	
	Apo NIR 40X W		40X III	—		—		—		—	
60X	Apo TIRF 60XC Oil Apo NIR 60X W	N2 Dry	60X I	—		—		—		—	
	Plan Fluor 60XS Oil Plan Fluor 60XC		60X II	NR Dry	60X I-R	N2 Oil	60X I	NR Oil	60X I-R		
	Plan Apo VC 60XC WI Plan Apo Lambda D 60X Oil Plan Apo IR 60XC WI		60X IV	60X II-R	60X IV-R	60X II	60X IV	60X II-R	60X IV-R		
100X	Plan Apo NCG 100X Oil Apo TIRF 100XC Oil	N2 Dry	100X I	—		—		—		—	
	Plan Fluor 100X Oil Plan Fluor 100XS Oil Plan Apo Lambda D 100X Oil		100X II	NR Dry	100X I-R	N2 Oil	100X I	NR Oil	100X I-R		
	Plan 100XC W		100X III	100X II-R	100X III	100X II	100X III	100X II-R	100X III		

For Ni-E (focusing nosepiece)/FN1 fixed stage microscopes

		FN-C LWD Condenser	
		Condenser Module	DIC Slider
10X	Plan Fluor 10X W	N1 Dry	10X
16X	LWD 16XW (CF75)		16X I
25X	Apo 25XC W Apo 25XC W 1300	N2 Dry	25X I

		FN-C LWD Condenser	
		Condenser Module	DIC Slider
40X	Apo NIR 40X W	N2 Dry	40X III
60X	Apo NIR 60X W		60X I
100X	Plan 100XC W		100X III

Epi-fluorescence Filter Cubes

Filter Cubes for Ni-E/U, Ci-E/Ci-L plus/Ci-S, Ti2-E/A/U, Ts2R-FL *1

Excitation	Filter Cubes	Wavelengths	Characteristics
UV	UV-1A	EX 365/10 DM 400 BA 390	•Narrow band pass—only 365 nm (i line) of Mercury spectrum used •Narrow band pass minimizes auto-fluorescence and photo-bleaching
	UV-2A	EX 355/50 DM 400 BA 410	•Standard filter cube for UV
	DAPI	EX 375/28 DM 415 BA 460/60	•For DAPI, cutting off FITC (green) and TRITC (red) •Soft-coated type for high signal/noise •Band-pass Barrier Filter used to cut off green and red
V	V-2A	EX 400/40 DM 430 BA 440	•Standard filter cube for V
BV	BV-2A	EX 420/40 DM 455 BA 460	•Standard filter cube for BV
B	B-2A	EX 470/40 DM 505 BA 510	•Standard filter cube for B •For FITC + Counter-stain (TRITC, PI)
	FITC	EX 480/30 DM 505 BA 535/45	•Soft coated type for high signal/noise •For FITC (green), cutting off Rhodamine red •Band-pass Barrier Filter used to cut off red
	GFP-B	EX 470/40 DM 500 BA 535/50	•Bandpass filter cube for GFP
G	G-2A	EX 535/50 DM 575 BA 580	•Standard filter cube for G
	TRITC	EX 540/25 DM 565 BA 605/55	•For TRITC (Rhodamine) •Soft coated type for high signal/noise •Band-pass Barrier Filter used to cut off reds above 643 nm
	Texas Red	EX 560/40 DM 595 BA 630/60	•For Texas Red® •Soft coated type for high signal/noise •Band-pass Barrier Filter used to cut off reds above 660 nm

*1 Only when the Ts2R-FL is used in combination with the external fiber light source.

High Quality Filter Cubes for Fluorescent Protein/Fluorophore

The HQ series causes minimal image shifts when superimposing multi-color images by adopting high-dimension accuracy glass. 32 mm diameter filter cubes for large FOV imaging are also available for the Ti2 series inverted microscope.

Filter Cubes	Wavelengths
DAPI-U HQ	EX 395/25, DM 425, BA 460/50
CFP HQ	EX 436/20, DM 455, BA 480/40
GFP HQ	EX 470/40, DM 495, BA 525/50
FITC HQ	EX 480/40, DM 510, BA 535/50
YFP HQ	EX 500/20, DM 515, BA 535/30
Cy3 HQ	EX 535/40, DM 565, BA 590/40
mCherry HQ	EX 570/40, DM 600, BA 645/75
Cy5 HQ	EX 620/60, DM 660, BA 700/75

Multi-Band Filter Cubes

Filter Cubes	Applications
Dual	DAPI/FITC
	CFP/YFP
	GFP/DsRed
	FITC/Texas Red
Triple	DAPI/FITC/TRITC
	DAPI/FITC/Texas Red

Note:

The lineup is constantly updated. For the latest information, please contact your local Nikon representative. The excitation filters or barrier filters in each filter cube are interchangeable. For custom setup, blank cubes without filters are also available. Please consult with your local Nikon distributor for a complete list of filters locally available or inquire about special custom filter combinations.

Filter Cubes for Ts2-FL/Ts2R-FL (LED illumination)

Filter Cubes	Wavelengths
C-LED385	EX 390/38, DM 420, BA 475/90
C-LED455	EX 448/23, DM 465, BA 472
C-LED470	EX 470/40, DM 500, BA 534/55
C-LED505	EX 496/29, DM 518, BA 543/37
C-LED525	EX 525/50, DM 560, BA 597/58
C-LED560	EX 550/50, DM 600, BA 630/75
C-LED590	EX 561/75, DM 610, BA 652/65
C-LED625	EX 621/58, DM 660, BA 706/73

Filter Cubes for SMZ25/18

Filters	Wavelengths
DAPI	EX395/25, DM425, BA460/50
CFP	EX436/20, DM455, BA480/40
GFP-B	EX460-500, DM505, BA510-560
GFP-L	EX460-500, DM505, BA510
YFP	EX500/20, DM515, BA535/30
RFP	EX530-560, DM570, BA590
mCherry	EX560/40, DM585, BA630/75

Dimensional Diagrams

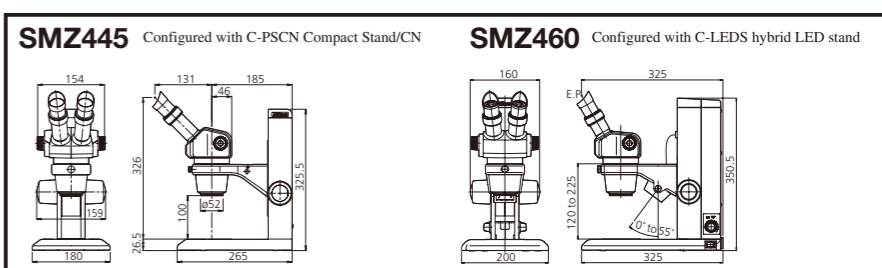
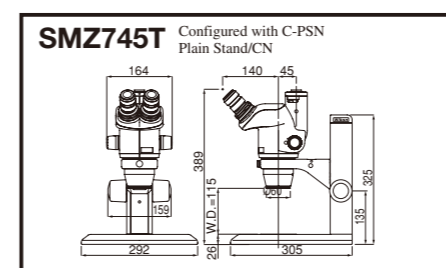
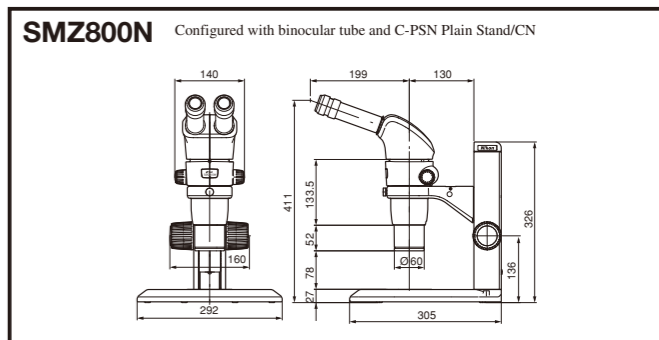
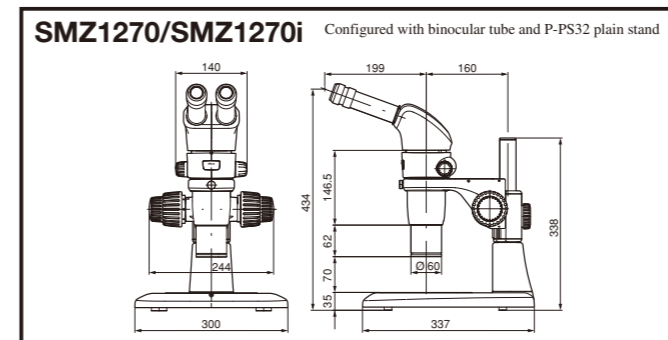
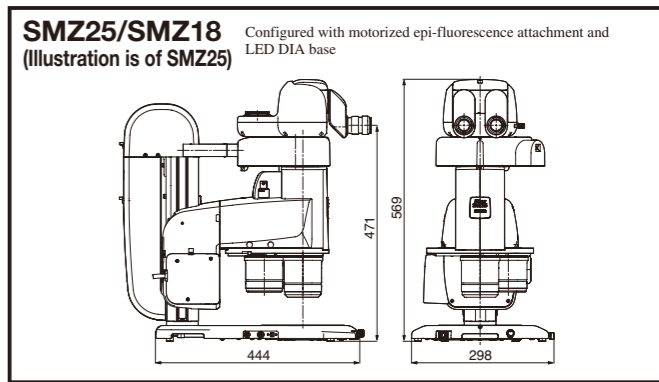
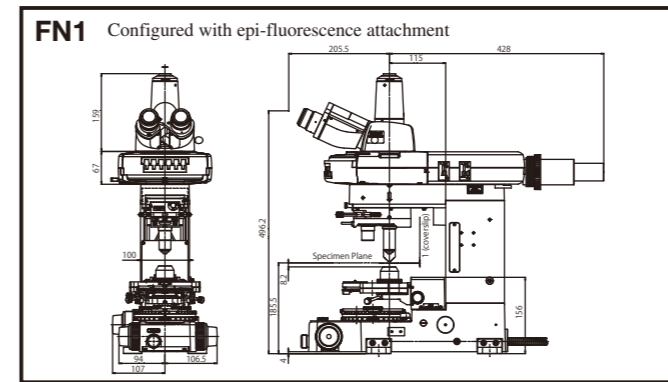
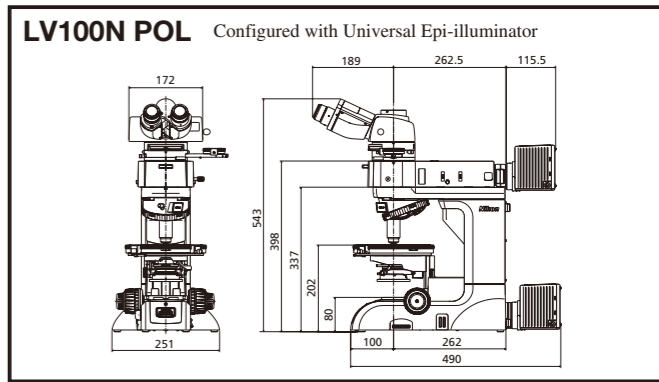
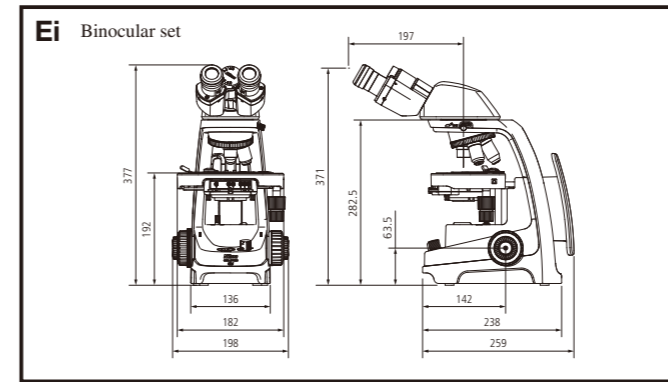
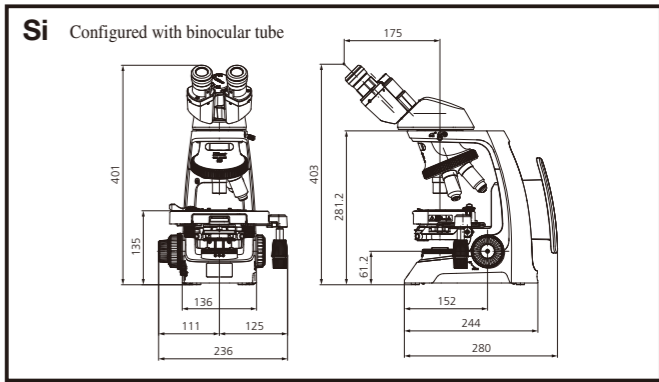
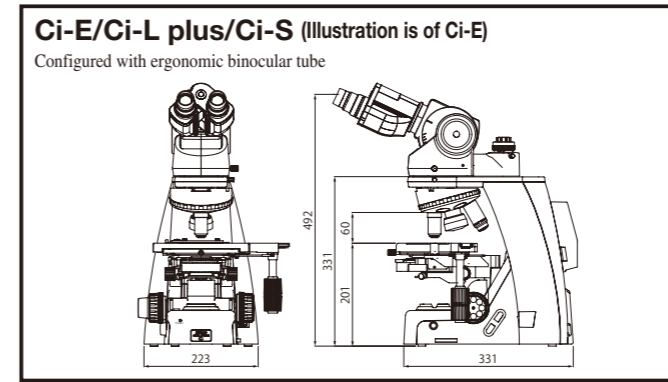
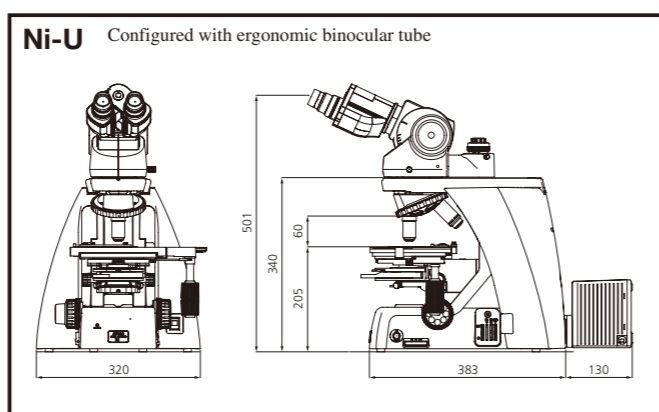
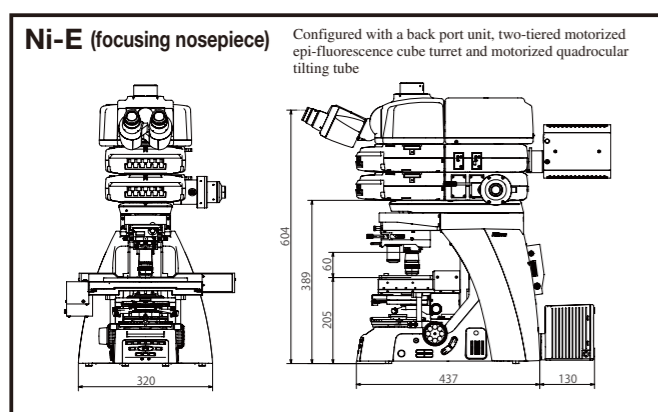
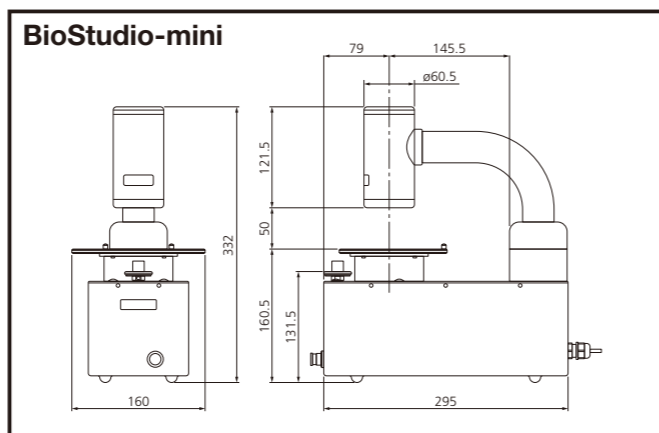
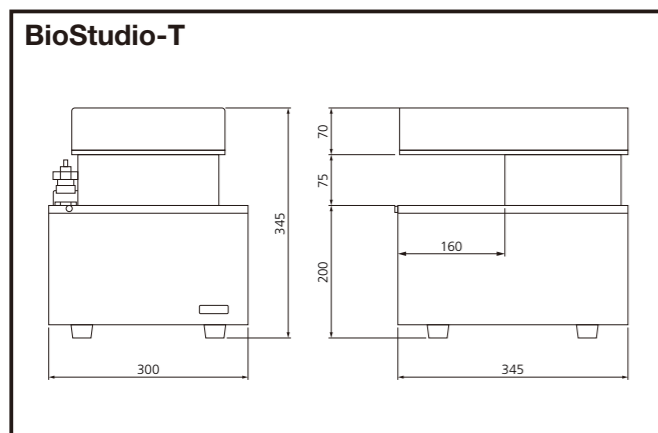
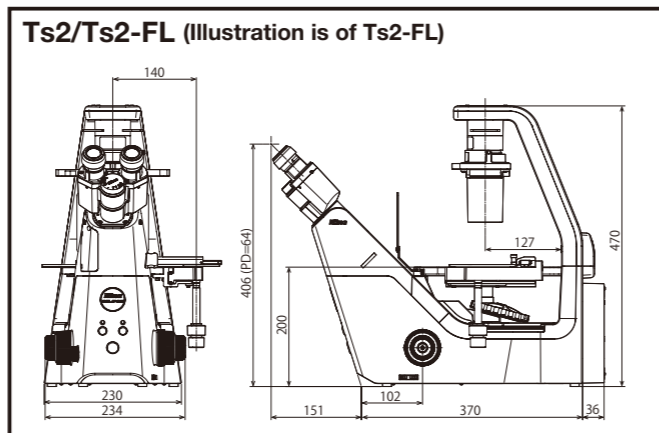
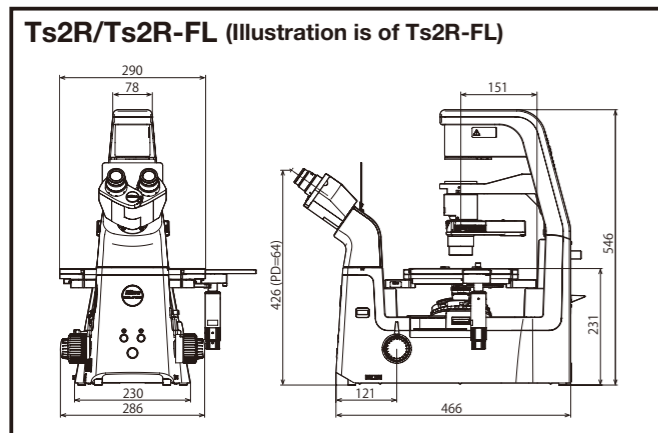
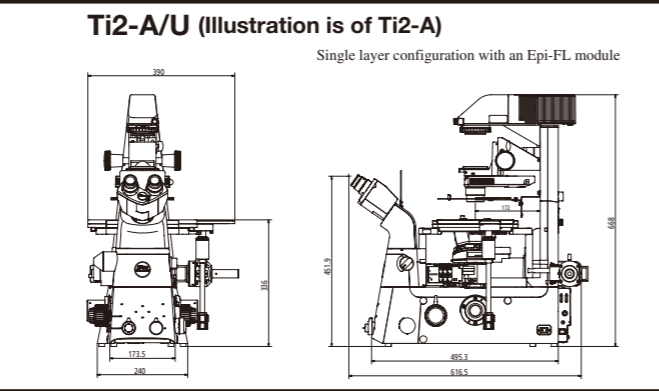
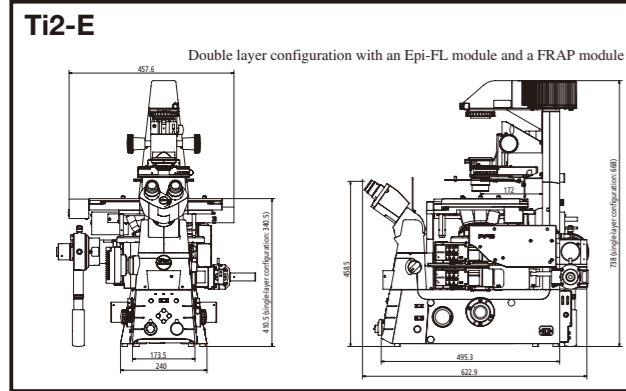

Eyepoint height: when pupillary distance is 64 mm Unit: mm

Eyepoint height: when pupillary distance is 64 mm Unit: mm